

# - KDE-TC DescaleJet

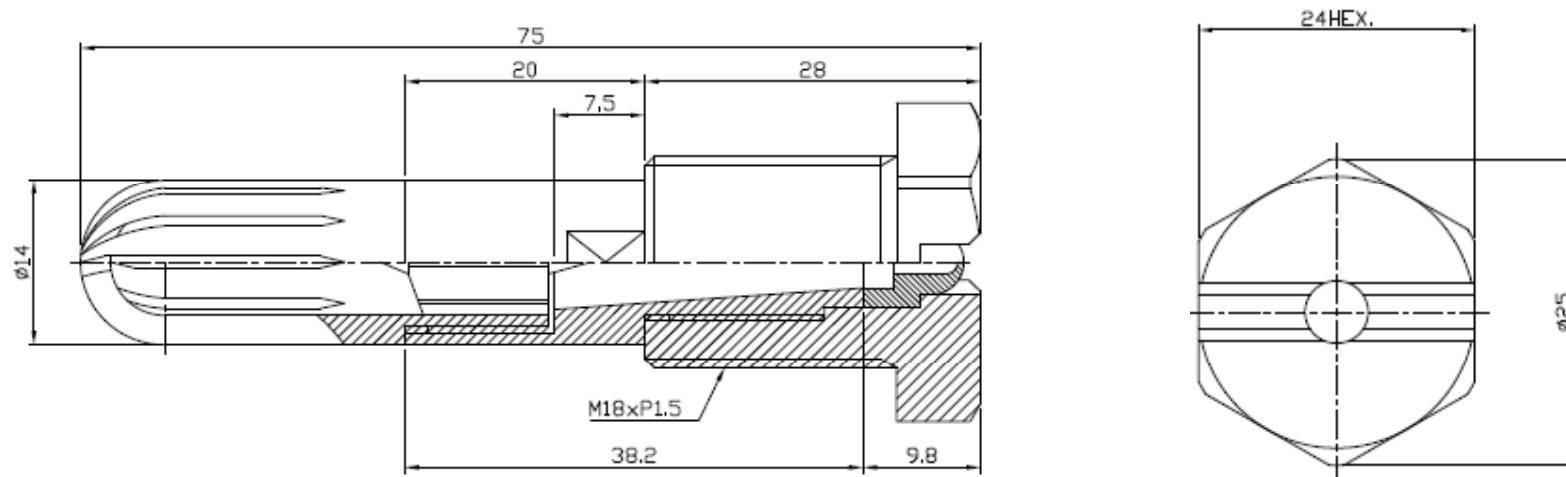

NOZZLE SIZE						CAPACITY l/min (LITERS PER MINUTE)										
SPRAY ANGLE AT 3 bar						20	25	30	40	50	60	70	100	150	200	275
0°	15°	25°	40°	50°	65°	bar	bar	bar	bar	bar	bar	bar	bar	bar	bar	bar
00007						0.71	0.80	0.87	1.0	1.1	1.2	1.3	1.6	2.0	2.3	2.6
0001	1501			5001		1.0	1.1	1.2	1.4	1.6	1.8	1.9	2.3	2.8	3.2	3.8
0002	1502		4002	5002		2.0	2.3	2.5	2.9	3.2	3.5	3.8	4.6	5.6	6.4	7.6
0003	1503			5003	6503	3.1	3.4	3.7	4.3	4.8	5.3	5.7	6.8	8.4	9.7	11.3
0004	1504	2504		5004	6504	4.1	4.6	5.0	5.8	6.4	7.1	7.6	9.1	11.2	12.9	15.1
	15045	25045				4.6	5.1	5.6	6.5	7.3	7.9	8.6	10.3	12.6	14.5	17.0
0005	1505	2505	4005	5005		5.1	5.7	6.2	7.2	8.1	8.8	9.5	11.4	14.0	16.1	18.9
00055	15055	25055				5.6	6.3	6.9	7.9	8.9	9.7	10.5	12.5	15.4	17.7	21
0006	1506	2506	4006			6.1	6.8	7.5	8.6	9.7	10.6	11.4	13.7	16.7	19.3	23
0007	1507	2507	4007	5007		7.1	8.0	8.7	10.1	11.3	12.4	13.3	16.0	19.5	23	26
0008	1508	2508	4008		6508	8.2	9.1	10.0	11.5	12.9	14.1	15.3	18.2	22	26	30
0009	1509	2509	4009		6509	9.2	10.3	11.2	13.0	14.5	15.9	17.2	21	25	29	34
0010	1510	2510				10.2	11.4	12.5	14.4	16.1	17.7	19.1	23	28	32	38
	1512					12.2	13.7	15.0	17.3	19.3	21	23	27	33	39	45
0015	1515		4015		6515	15.3	17.1	18.7	22	24	26	29	34	42	48	57
0018						18.3	21	22	26	29	32	34	41	50	58	68
0020						20	23	25	29	32	35	38	46	56	64	76

