



# SOLID DOSAGE PROCESSING

	PAGE
Application Overview	81
Fluid Air, a Division of Spraying Systems	82
Fluid Bed Systems	83
High-Shear Granulators	87
Size-Reduction Systems	89
Electrostatic Spray Dry Systems	91
Tablet Coating Systems	93
Control Options and More	95



# PERFECTING THE PROCESS

In the pharmaceutical industry, a solid dose is a dosage form, such as a tablet or capsule or powder which is ingested orally and generally consists of a mixture of active pharmaceutical ingredients (or APIs, the drugs being delivered) along with a combination of binders, fillers and other excipients designed to imbue the finished drug with specific characteristics. Processing methods for individual pharmaceutical drugs can vary widely depending on the type or types of drugs being manufactured, the dosage form (solid dosage vs. liquid) the intended route of administration, and the necessary duration of the API's release into the human body to achieve the pharmacological effects of the drug.

Two solid dosage forms, tablets and capsules, are among the most common drug dosage forms for consumers. Formulating the fill for capsules is generally easier than for tablets, but they are both manufactured using similar processes.

## ONLINE RESOURCES

For more information on equipment for solid dosage processing, visit [fluidairinc.com](http://fluidairinc.com).





## Experts in Solid Dosage Technology

A Division of *Spraying Systems Co.*®

### MAGNAFLO® Fluid Bed Systems



### PHARMX® High-Shear Granulators



### GRANUMILL® Size Reduction Systems

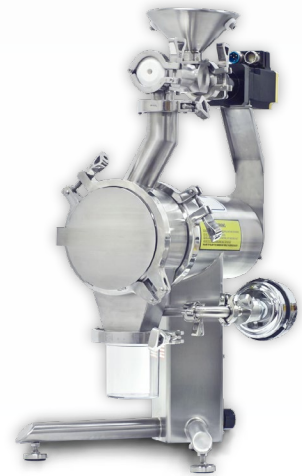

## FLUID AIR, A DIVISION OF SPRAYING SYSTEMS CO.®

Fluid Air is a division of Spraying Systems Co. specializing in solid dosage processing equipment for the pharmaceutical industry, including fluid bed dryers/granulators, Wurster coaters, high-shear granulators, size reduction systems and process control software for batch-type equipment.

Available in a full range of sizes from R&D to production scale, Fluid Air systems are designed to provide superior performance and batch uniformity for solid dosage processing applications while maintaining important process parameters from one size system to the next, making it easy for users to predict scale-up results. Configurable with a wide variety of optional features, each system is completely customizable to fit your exact specifications and process requirements, ensuring the perfect fit—no matter how challenging the application.

### ONLINE RESOURCES

For more information on Fluid Air systems, visit [fluidairinc.com](http://fluidairinc.com).

## MAGNAFLO® & MAGNACOATER® FLUID BED SYSTEMS

### PRODUCT OVERVIEW

MAGNAFLO fluid bed dryer/granulators and MAGNACOATER Wurster coaters are completely customizable fluid bed systems designed to provide superior performance for solid dosage processing applications from R&D to production scale.



**R&D SCALE**  
MODELS 0002, 0005

R&D or laboratory-scale units provide effective drying, coating or granulation for small batches.



**PILOT SCALE**  
Models 0010 - 0120

Pilot systems offer a wide range of options for processing larger batches intended for clinical trial or small-scale production.



**PRODUCTION SCALE**  
MODELS 0300 - 1200

Production scale fluid bed systems for processing of very large batches (up to 1200 Liters).

### FEATURES AND BENEFITS

- Tapered expansion chamber improves granulation and reduces process time
- Agitator rake in bowl bottom ensures bed homogeneity
- Conidur and Turboflo bed plates provide uniform air distribution
- Specific geometry maintains critical scale-up factors
- Adjustable “shutter” plate allows for precise, user-controlled coating (MAGNACOATER Only)

## SPECIFICATIONS – MAGNAFLO® &amp; MAGNACOATER® FLUID BED SYSTEMS

Model Number	0002	0005	0010	0020	0050	0120	0300	0500	0800	1000	1200
Standard bowl volume (L)	2.0	13	20	46	57	148	346	617	967	1205	1437
Max. granulating capacity (L)	2	5	10	34	51	133	311	555	870	1084	1293
Max. coating capacity (L)	1.8	6	10	31	46	124	193	477	720	n/a	n/a
Extended bowl volume (L)	*	*	*	n/a	72	207	482	860	1346	1645	1961
Reduced volume bowls (L)	0.5	2	2, 5	5, 10	5, 46	46, 72 57, 97	148	346, 148	n/a	n/a	n/a
System height (inches/mm)	72/ 1829	74/ 1880	80/ 2032	105/ 2667	130/ 3302	138/ 3505	160/ 4064	148/ 3670	174/ 4420	185/ 4699	192/ 4877
System width (inches/mm)	32/ 813	76/ 1930	78/ 1981	36/ 1981	48/ 1220	46/ 1168	72/ 1829	84/ 2134	96/ 2538	105/ 2667	114/ 2896

## MAGNALIFT® BIN & BOWL ELEVATORS

### PRODUCT OVERVIEW

MAGNALIFT bin and bowl elevators elevate, invert, or rotate to blend fluid bed bowls or bins for sanitary discharge into a tablet press, drum, or other process equipment. With options ranging from height, material use, movement, and more, each MAGNALIFT is fully customized to meet your specific process needs.

### FEATURES AND BENEFITS

- Safe and robust construction
- GMP design for use in washdown environments
- Custom configured for each special application to meet loading and unloading requirements
- Pivoting or stationary posts with floor and ceiling or floor only support
- Inverting and/or lift only configurations
- Hydraulically driven for efficient movement, safety, and speed



## MODEL 0002 FLUID BED SYSTEM WITH ULTRASONIC AIR ATOMIZING LANCE

### PRODUCT OVERVIEW

The Model 0002 fluid bed system for R&D applications is now available with integrated ultrasonic spray technology for superior performance in fluid bed coating, granulation, fluid bed drying and spray drying.

### FEATURES & BENEFITS – MODEL 0002 FLUID BED SYSTEM

- Conidur plates ensure uniform air distribution through the bed
- Unique Wurster plate design ensures proper flow of material
- Easy-to-use controls, adjustable touch screen and data logging
- Spraying Systems Co. nozzles provide superior spray distribution
- High-retention filter system reduces product waste
- Precise, in-process air flow and temperature controls for improved batch accuracy

### ULTRASONIC AIR ATOMIZING LANCE

- Patent-pending design provides superior accuracy in spray pattern formation
- Gentle Wurster coating of fine particles 30 microns or smaller
- Ultra-fine Ultrasonic spray prevents agglomeration
- Adjustable shaping air pressure allows users to achieve the desired liquid droplet velocity
- Flow rates range from 0.5 cc/min to 10 cc/min



**SPECIFICATIONS – MAGNAFLO® & MAGNACOATER® FLUID BED SYSTEMS**

Ultrasonic bowl volume (L)	1/2
Ultrasonic bowl volume (mL)	72 / 1829
System width (inches / mm)	32 / 813

**ULTRASONIC AIR ATOMIZING LANCE**

Nozzle orifice diameter: 0.03" (0.762 mm)
Droplet size range: 10-90µm
1/8" NPTF connections (shaping/cooling air inlets and exhaust)
1/2" hygienic liquid inlet connection
316SS lance with titanium ultrasonic horn
Choice of FDA VITON or EPDM elastomers

**SPRAY TIP: ACHIEVE MICRON-LEVEL COATING PRECISION WITH INTEGRATED ULTRASONIC TECHNOLOGY**

Ultrasonic spray technology delivers the precise, uniform spray required for delicate, complex fluid bed coating processes— such as Wurster (fluid bed) coating— while providing a high level of control over the spray, allowing users to make fine adjustments on the fly. Fluid Air will work with you to integrate Ultrasonic spray technology into your customized fluid bed processor.

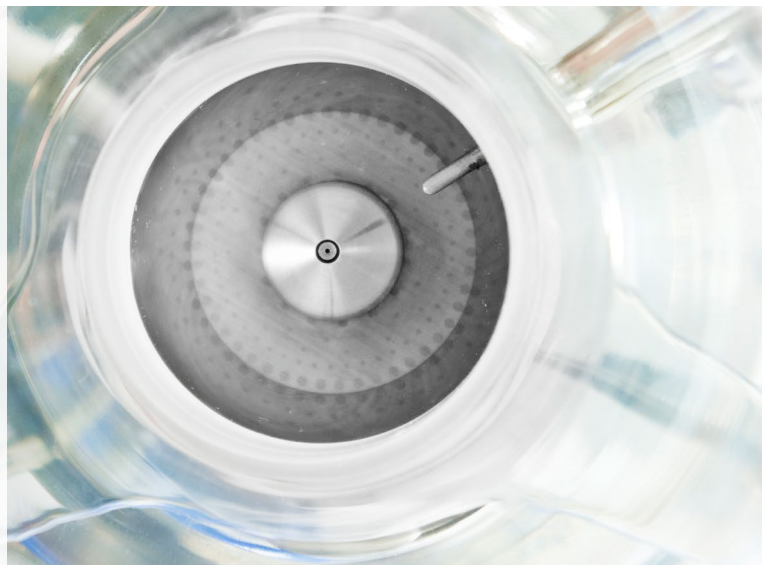

PHARMX<sup>®</sup> HIGH-SHEAR GRANULATORS

## PRODUCT OVERVIEW

PHARMX high-shear granulators are fully customizable bottom-driven mixing systems engineered to provide homogeneous mixing and efficient granulation across a range of available R&D, pilot, and production size models.



### R&D SCALE

PX1

R&D or laboratory-scale units provide effective high-shear granulation for small batches.



### PILOT SCALE

PX25 - PX150

Pilot systems offer a wide range of options for processing larger batches intended for clinical trial or small-scale production.



### PRODUCTION SCALE

PX250 - PX1250

Production scale systems for granulating very large batches (up to 1250 Liters).

## FEATURES AND BENEFITS

- Optimized bowl geometry allows for efficient mixing at up to 90% capacity
- Hydraulic drive system
- Bottom-driven mixing impeller and high-speed chopper ensure uniform mixing
- One-pot processing models available (mixing/drying)
- Water jacketing, vacuum loading/drying and nitrogen inerting options



## SPECIFICATIONS – PHARMX® HIGH-SHEAR GRANULATORS

Model Number	PX1	PX25	PX50	PX100	PX150	PX250	PX400	PX600	PX800	PX1000	PX1250
Total bowl volume (L)	1, 2, 4, 6, 8, 4	31	58	119	167	274	432	633	864	1050	1286
Charge- max. liters @ light bulk, 0.3 - 0.5	0.9 - 7.5	28	58	107	150	246	389	569	778	945	1157
Charge- min. liters	0.3 - 2.5	8	15	30	42	69	109	159	218	265	324
Impeller speed range (RPM)	5 - 1107	37 - 318	29 - 260	14 - 205	12 - 185	10 - 172	1 - 148	1 - 127	1 - 118	1 - 110	1 - 103
Impeller power (HP)	0.5 - 1	3	5	10	15	40	50	75	100	125	150
Chopper speed range (RPM)	1500 - 9750	500 - 4000	500 - 4000	500 - 4000	500 - 4000	500 - 4000	500 - 3000	500 - 3000	500 - 3000	500 - 3000	500 - 3000
Chopper power (HP)	0.25	1	2	5	7.5	10	15	20	25	30	40

### SPRAY TIP: PROCESS HAZARDOUS COMPOUNDS SAFELY WITH INTERCHANGEABLE BOWLS

For processing potent compounds requiring total containment, we are able to provide customized interchangeable bowls. The bowls can be removed from the console and placed in a glove box / flexible containment structure without any dusting of product from the bowl. Charging and discharging from the mixer bowl is completely contained.



**GRANUMILL® SIZE REDUCTION SYSTEMS****PRODUCT OVERVIEW**

GRANUMILL size reduction systems are wet and dry mill systems designed for precision particle size reduction and de-agglomeration applications, available in R&D, pilot, and production scale sizes.



**R&D SCALE**  
**GRANUMILL Jr.**

R&D or laboratory-scale units provide effective size reduction or de-agglomeration for small batches.



**PILOT SCALE**  
**GRANUMILL 007**

Pilot systems offer a range of options for larger batches intended for clinical trial or small-scale production.



**PRODUCTION SCALE**  
**GRANUMILL 014**

Production scale systems for very large batches.

**FEATURES AND BENEFITS**

- Variable speed rotor allows for both high-speed fine grinding and low speed de-agglomeration
- Quick-release housing allows mill to be broken down in minutes for cleaning or inspection
- Robust rotor design available in three different shapes – square/flat, round, and knife
- Water jacketed housing available for temperature-sensitive products
- Quiet operation
- Multiple feed and discharge options available to suit your process



## SPECIFICATIONS – GRANUMILL® SIZE REDUCTION SYSTEMS

Model Number	GRANUMILL Jr.*	GRANUMILL 007*	GRANUMILL 014*
Speed (RPM)	500 - 10000	500 - 5000	600 - 3600
Finished particle size mesh (micron)	10 - 400 (2000 - 27)	10 - 400 (2000 - 27)	10 - 400 (2000 - 27)
Throughput (lbs/kg)/hour	0.2 - 60 / 0.1 - 25	2 - 2250 / 1 - 1000	4 - 3860 / 2 - 1750
System Height (inches/mm)	25 - 635	80 / 2032	80 / 2032
System Width (inches/mm)	12 / 304	32 / 813	40 / 1016
System Length (inches/mm)	15 / 381	60 / 1524	68 / 1727
Screen Width (inches/mm)	4 / 102	7 / 178	14 / 356

### SPRAY TIP: SAVE TIME AND MONEY WITH FLEXIBLE CONTAINMENT ENCLOSURES

In cooperation with ILC-Dover, we are able to provide custom-designed, flexible containment systems for GRANUMILL Jr. size reduction systems. The flexible enclosure set-up allows for use in both containment and non-containment applications, eliminating the need to purchase a second machine solely for containment use.



## POLARDRY™ ELECTROSTATIC SPRAY DRY SYSTEMS

### PRODUCT OVERVIEW

The patent-pending PolarDry™ Electrostatic Spray Dryer utilizes revolutionary electrostatic technology, which drives water or solvent to the shell and active to the core, lowering the required evaporation temperature and eliminating active ingredient loss, degradation, or denaturalization. Harnessing the electrostatic effect, the dispersed active driven into the core is microencapsulated, virtually eliminating surface active, resulting in stunning encapsulation efficiency.

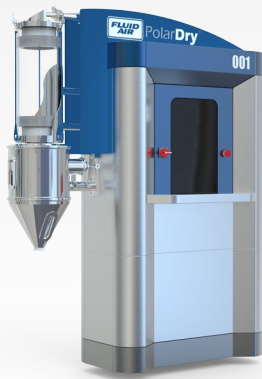

#### FEASIBILITY SCALE MODEL 001

A portable PLC controlled once-through design intended for a laboratory environment. This GMP designed machine is the best option for feasibility checks.



#### R&D SCALE Model 004

A semi-portable PLC controlled recirculating system for R&D Environments. This unit uses the same nozzle as Model 032 for easy scale-up. This model includes portable access stairs with a work platform.



#### PILOT SCALE MODELS 032 & 050+

Model 032 is a modular design, PLC controlled system for Pilot Environments. Choose from Batch Architect™ or Batch Architect Pro™ with CFR21 PART11 Compliant Data Logging to control this intermediate system. This model includes access stairs with a work platform.

### FEATURES AND BENEFITS

- Low operating temperature allows for greater encapsulation efficiency for high-volatile components
- SAFE - Nitrogen Inerted
- Inner liner makes for easy clean-up/changeover
- Process products with low glass transition temperature (Tg)
- Recycled process gas with negligible emissions virtually eliminates regulatory issues
- The ability to agglomerate the powder as it is being dried

**SPECIFICATIONS – POLARDRY™ ELECTROSTATIC SPRAY SYSTEMS**

<b>Model Number</b>	<b>001</b>	<b>004</b>	<b>032</b>	<b>050+</b>
Nominal Evaporation Rate (kg/hr)	1	4	32	50
Minimum Drying Temperature (°C)	20*	10	10	10
Maximum Drying Temperature (°C)	140	140	140	140
Maximum Drying Gas Flow (m3/hr)	42	170	1020	1784
Maximum Atomizing Gas Flow (m3/hr)	10	17	68	120
Collection Volume (liters)	1	20	14**	20**
Drying Gas Heater	Electric	Electric	Electric	Indirect Gas
Gas Handling	Once Through	Recirculating	Recirculating	Recirculating
Feed Stock Pump	Yes	Yes	Yes	Yes
Nozzle Clog Monitoring	No	No	Yes	Yes
WIP Nozzles Included	Yes	Yes	Yes	Yes
Filter Systems	Patented Reverse Pulse Bag	Patented Reverse Pulse Bag	Reverse Pulse Cartridge	Reverse Pulse Cartridge
Controls	NEMA 4X	NEMA 4X	NEMA 4X	NEMA 4X
Controls Software	Batch Architect™	Batch Architect™	Batch Architect™***	Batch Architect™***

\*Dependent on inlet gas supply temperature    \*\*Pneumatic or Cable Conveyor Available    \*\*\*Batch Architect Pro™ Available for CFR21 Part 11 Compliance

**SPRAY TIP: REDUCE POST-PROCESSING WITH CONTROLLED AGGLOMERATION**

By controlling the voltage applied to the spray droplet as it is being atomized, some particles form an outer shell readily while others develop their shell gradually resulting in a wet or tacky particle. As these two types of particles collide, they bond forming an agglomerated particle. This results in a finished product with larger particles and fewer fines which flow freely.

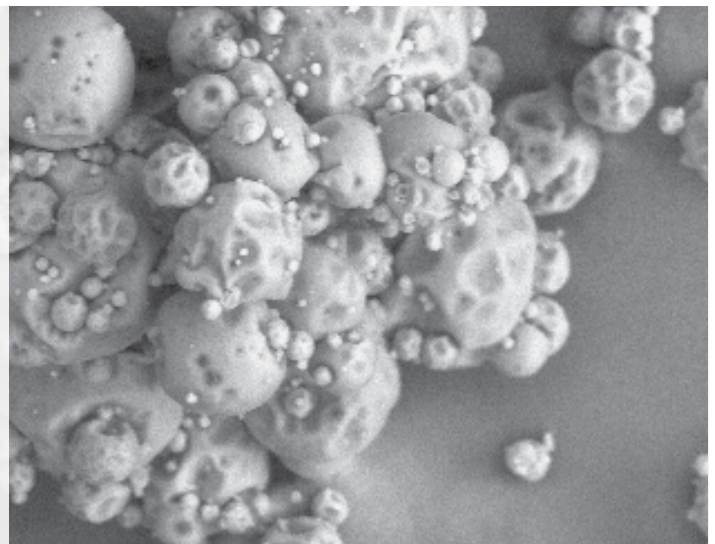

## TABCOATER® TABLET COATING OPTIMIZATION SYSTEM

### PRODUCT OVERVIEW

Replacing a costly tablet coater or coating pan is not the only way to improve coating results. Designed to upgrade only the core components of your existing coater, the new TABCOATER system is a flexible solution for improving the performance of aging coating equipment.

### PACKAGE FLEXIBILITY: CHOOSE COMPLETE SYSTEM OR INDIVIDUAL UPGRADES

The complete TABCOATER system consists of a manifold, spray nozzles, a fluid delivery skid, and process controls. Whether you're looking to change your entire coating system or just need to replace a worn out spray nozzle, Spraying Systems and Fluid Air will work with you to customize a solution that fits your requirements.

### FEATURES & BENEFITS

#### MANIFOLD WITH VMAU SPRAY NOZZLES

- Patent-pending internal recirculating guns
- Prevents tablet entrapment
- Anti-bearding nozzles reduce product build-up

#### BATCH ARCHITECT™ PROCESS CONTROLS

- Automates fluid delivery skid or entire pan operation
- Phase or recipe-based controls

#### CUSTOMIZED FLUID DELIVERY SKIDS

- Custom GMP design configured for process area
- Closed-loop solution/liquid delivery metering using loss-in-weight, mass flow sensing, and totalizing
- Precise, low-pulsation peristaltic pumps eliminate "dead-leg" liquid distribution
- Liquid flow shut-off with optional recirculation
- Nozzle liquid feed pressure sensors detect clogging
- Nozzle clearing circuit, line clearing and purge system
- Atomizing and fan air pressure control with flow

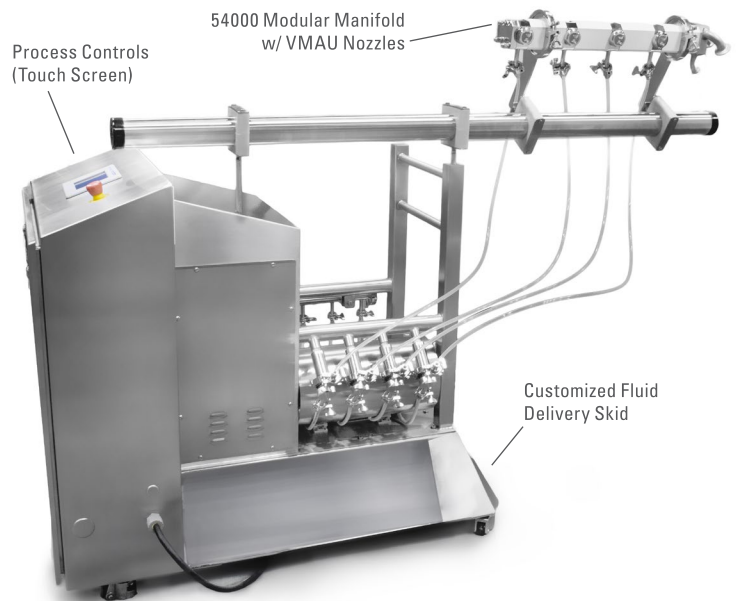

### ONLINE RESOURCES

- ▶ Website [Fluidairinc.com](http://Fluidairinc.com)

**DIMENSIONS – TABCOATER® TABLET COATING OPTIMIZATION SYSTEM**

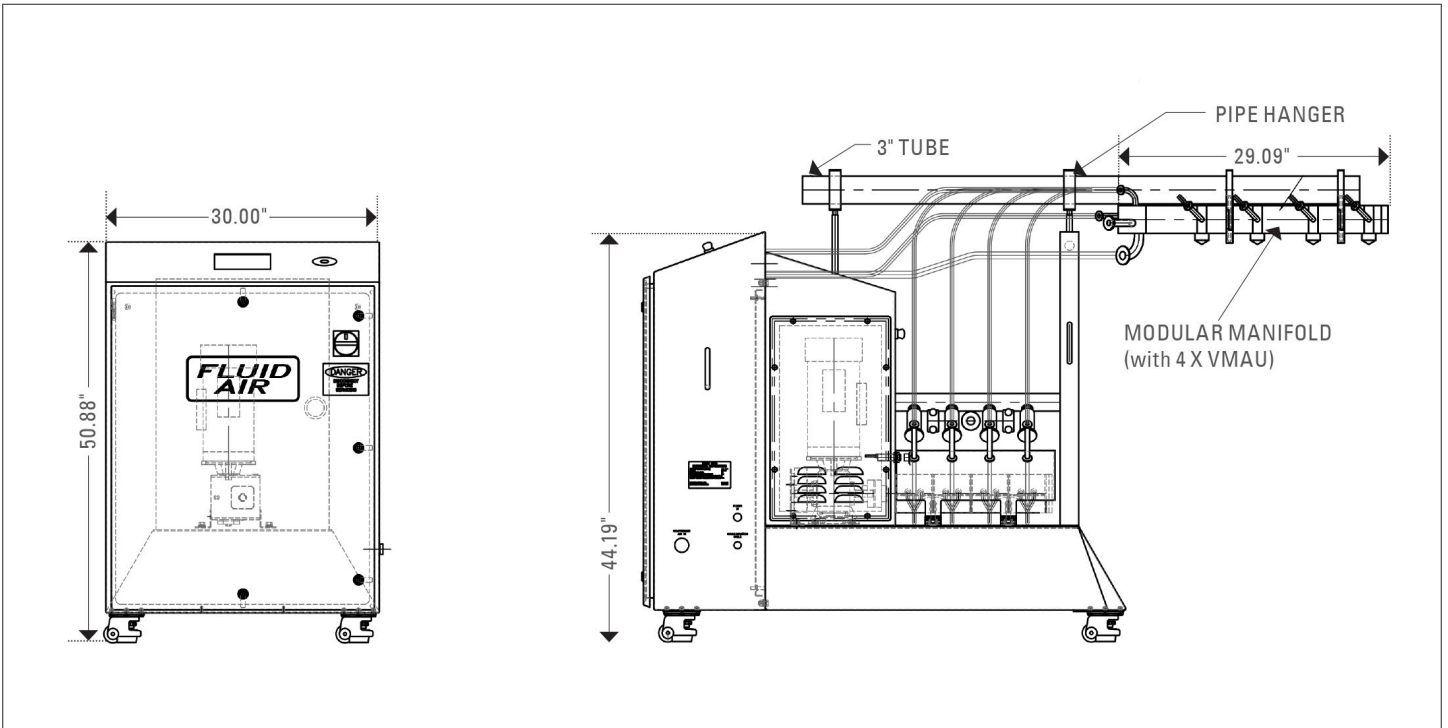

**SPRAY TIP: SAVE MONEY WITH  
INDIVIDUAL UPGRADES**

The complete TABCOATER system consists of a manifold, spray nozzles, a fluid delivery skid, and process controls. Whether you're looking to change your entire coating system or just need to replace a worn out spray nozzle, Fluid Air will work with you to customize a solution that fits your requirements.

For more information on TABCOATER systems, visit [fluidairinc.com](http://fluidairinc.com).



## BATCH ARCHITECT™ PROCESS CONTROL SOFTWARE

### PRODUCT OVERVIEW

Fluid Air systems run on Batch Architect process control software, a flexible solution for controlling virtually any batch-type equipment. The easy-to-use software allows users to control complex pharmaceutical processing equipment with little to no training, and is available in either standard or Pro versions.

### FEATURES AND BENEFITS

- Provides direct access to manual machine control and optional features for increased automation
- Equipped with a graphical user interface which provides current status information of critical machine functions through animation and text
- Runs on FactoryTalk® HMI platform and Allen-Bradley Logix™ series processors
- Recipe control feature allows batches to be easily created, stored, and reproduced
- 21 CFR Part 11 Capability (Pro Version Only)
- Offers convenient electronic batch record data logging and report creation services
- Increased product lifecycle through virtualization technology



Batch Architect™

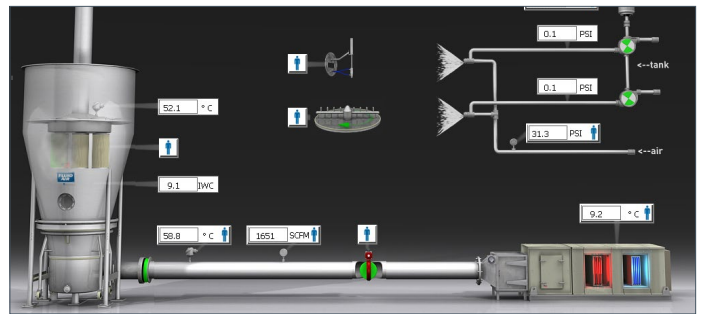

Batch Architect™ Pro Status Screen

### SPRAY TIP: REDUCE COSTS WITH SOFTWARE VIRTUALIZATION TECHNOLOGY

As software development teams move through the software development lifecycle and new software versions are created to improve the product, the use of “virtual machines” can now store a simple file containing the entire operating system configuration. Systems running on Batch Architect Pro can use these virtual machine files to save time and considerable cost during set-up, also reducing the need for spare legacy hardware.





## RETROFIT SERVICES AND MORE

### SERVICE OVERVIEW

In addition to new equipment, Fluid Air offers a range of services to make your used machines feel like new again. Update your process with the latest in spray technology, process controls, retrofit services and more provided by our global network of trained sales and support personnel.

### FEATURES AND BENEFITS

- Upgrade almost any type and brand of pharmaceutical batch-type processing equipment
- Convert equipment to perform new functions, like fluid bed granulating or Wurster coating
- Add new features to existing equipment such as humidification, modern filter systems, solvent recovery systems and more
- Update your existing control system to robust, recipe-driven Batch Architect™ process control software



Model 0002 Fluid Bed



Tablet Coater Operating with Batch Architect™ Process Control Software

### SPRAY TIP: REVITALIZE YOUR EXISTING EQUIPMENT WITHOUT REPLACING IT

Replace your worn or existing factory-supplied nozzles with new, state-of-the-art fluid bed nozzles from Spraying Systems Co. Intended to fit either new or existing Fluid Air fluid bed systems as well as competitor systems, our line of customizable nozzles and lances for Wurster coating and top-spray granulation are designed to help you get the most out of your machine.

