

| ECO NO. | DATE | REVISION & DESCRIPTION | REVWED | CHECKED |
|---------|------|------------------------|--------|---------|
| △ | | | | |
| △ | | | | |

< Lift >

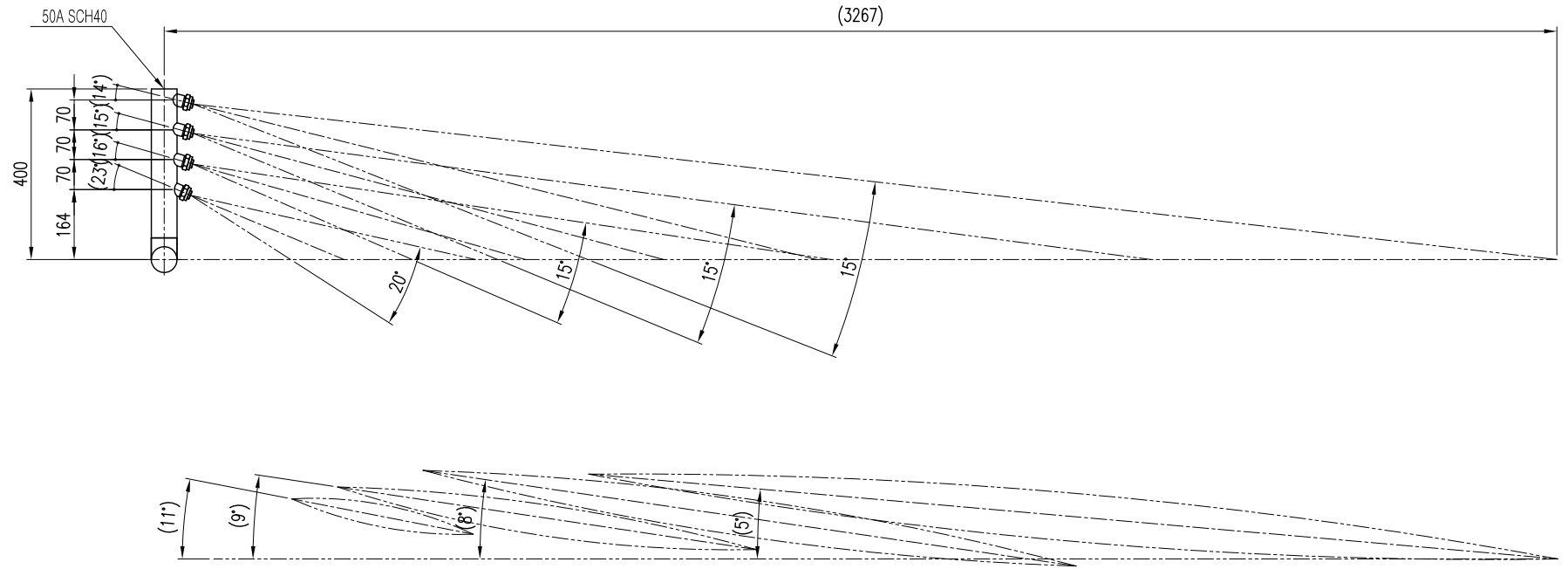

| 5 | 50A ELBOW | SUS304 | 1 | |
|------|----------------|----------|------|---------|
| 4 | RETAINERRING | SUS303 | 4 | |
| 3 | BODY | SUS304 | 4 | |
| 2 | TIP | SUS303 | 4 | |
| 1 | PIPE 50A SCH40 | SUS304 | 1 | |
| ITEM | COMPONENT | MATERIAL | Q'TY | REMARKS |

| | | | |
|-------|--------------|------------|--|
| DESC. | KHD163577-SS | CUSTOMER : | |
| | SPRAY HEADER | | |

| | | | |
|---------|---------|----------|----------------|
| APP BY. | CH BY. | DES BY. | PRODUCT NAME : |
| B.S.KIM | J.M.LEE | J.H.JUNG | |

| | | |
|-------------|--------------|---------------|
| | SCALE : | CREATE DATE : |
| | 1:1 | 2017.08.14 |
| THIRD ANGLE | DWG. NO. : | |
| | 56163-577-C1 | |

지시외 용접치수 절삭가공치수의 지시외 일반치수 허용차 (KS B ISO2768-1 중급)

| 구분 | 0.5 이상 3 이하 | 3 을초과 6 이하 | 6 을초과 30 이하 | 30 을초과 120 이하 | 120 을초과 400 이하 |
|-----|----------------|---------------|----------------|------------------|-------------------|
| 허용차 | ±0.1 | ±0.1 | ±0.2 | ±0.3 | ±0.5 |

SPECIFICATION

| | |
|--|----------------------|
| PRESSURE (XXX) (kg/cm ²) | SPRAY ANGLE (±7°) |
| | (XXX)~(XXX)~(XXX) |
| | (XXX)~(XXX)~(XXX) |
| | CAPACITY (ℓ/min ±7%) |

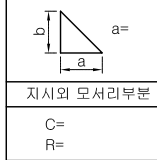

| CHECK LIST | | | | | ECO NO. | DATE | REVISION & DESCRIPTION | REVISED | CHECKED |
|------------|-----------|-----------|----------|--|---------|------|------------------------|---------|---------|
| LENGTH | ITEM NAME | CONNECTOR | CAPACITY | | | | | | |
| WIDTH | MARKING | ORIFICE | COMMENT | | | | | | |

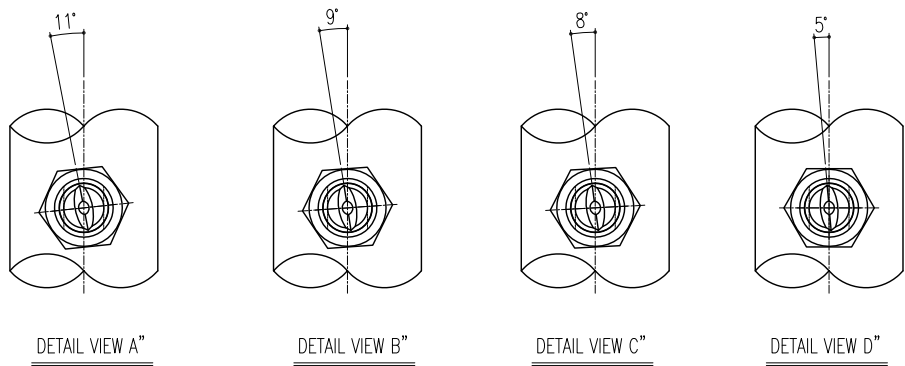
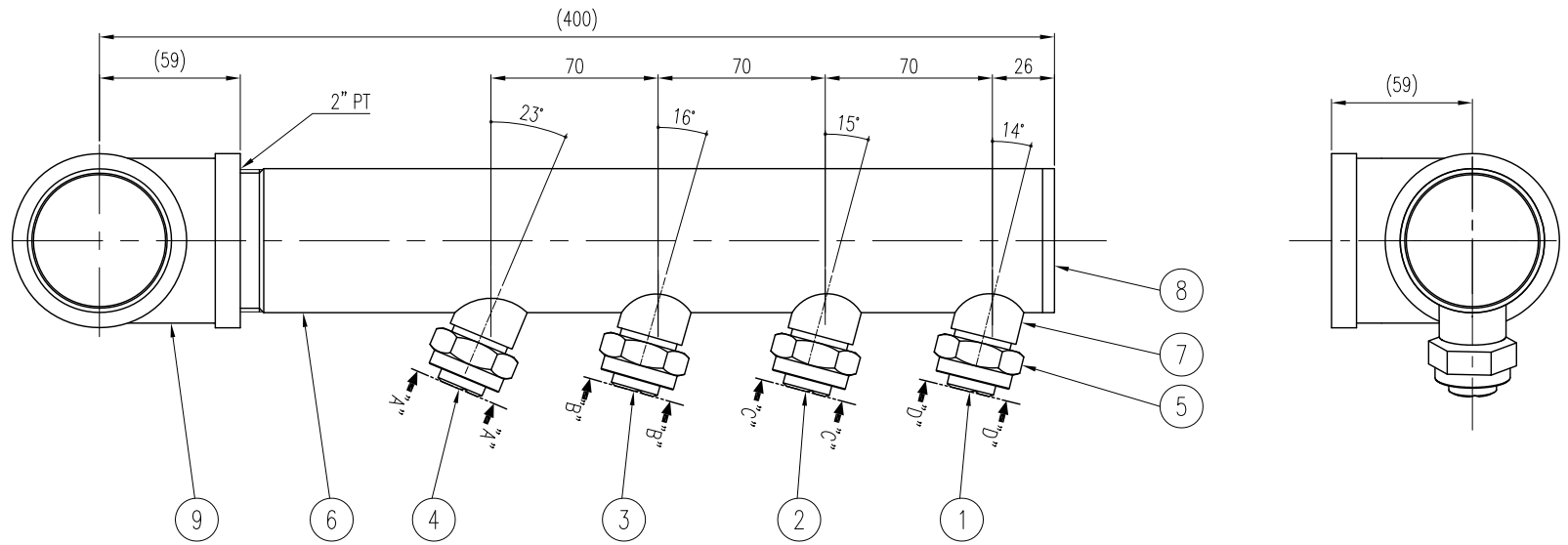

| 9 | 50A SCREW ELBOW | SUS304 | 1 | |
|------|---------------------------------|----------|------|---------|
| 8 | END PLATE | SUS304 | 1 | |
| 7 | BODY | SUS304 | 4 | |
| 6 | PIPE 50A SCH40 | SUS304 | 1 | |
| 5 | RETAINER RING(KRT3/4-167105-SS) | SUS303 | 4 | |
| 4 | TIP(KDTP18897-2080-SS-01) | SUS303 | 1 | |
| 3 | TIP(KDTP18897-1580-SS-04) | SUS303 | 1 | |
| 2 | TIP(KDTP18897-1580-SS-03) | SUS303 | 1 | |
| 1 | TIP(KDTP18897-1580-SS-01) | SUS303 | 1 | |
| ITEM | COMPONENT | MATERIAL | Q'TY | REMARKS |

| | | | | |
|-------|--------------|------------|--|--|
| DESC. | KHD163577-SS | CUSTOMER : | | |
| | SPRAY HEADER | | | |

| | | | | |
|-------------|---------|-------------------------|----------------|--|
| APP BY. | CH BY. | DES BY. | PRODUCT NAME : | |
| J.M.LEE | J.H.YOU | J.H.JUNG | | |
| SCALE : 1:1 | | CREATE DATE : | | |
| THIRD ANGLE | | DWG. NO. : 56163-577-A1 | | |

| 지시와 용접치수 | | | | | | | SPECIFICATION | | | | | | |
|--|--|--|--|--|--|--|----------------------|-------------------------------|--|--|--|--|--|
| 절삭가공치수의 지시와 일반치수 허용차 (KS B ISO2768-1 중급) | | | | | | | PRESSURE | SPRAY ANGLE (±7°) | | | | | |
| 구 분 | | | | | | | | (XXX)~(XXX)~(XXX) | | | | | |
| 허용 차 | | | | | | | | (XXX)~(XXX)~(XXX) | | | | | |
| 지시와 모서리부분 | | | | | | | CAPACITY (ℓ/min ±7%) | SURFACE ROUGHNESS (KS B 0617) | | | | | |
| 다듬질기호 | | | | | | | | (XXX) (kg/cm²) | | | | | |
| Rmax | | | | | | | | 100S 25S 6.3S 0.8S | | | | | |



| | | | | |
|---------|------|------------------------|--------|---------|
| ECO NO. | DATE | REVISION & DESCRIPTION | REVWED | CHECKED |
| △ | | | | |
| △ | | | | |

< Right >

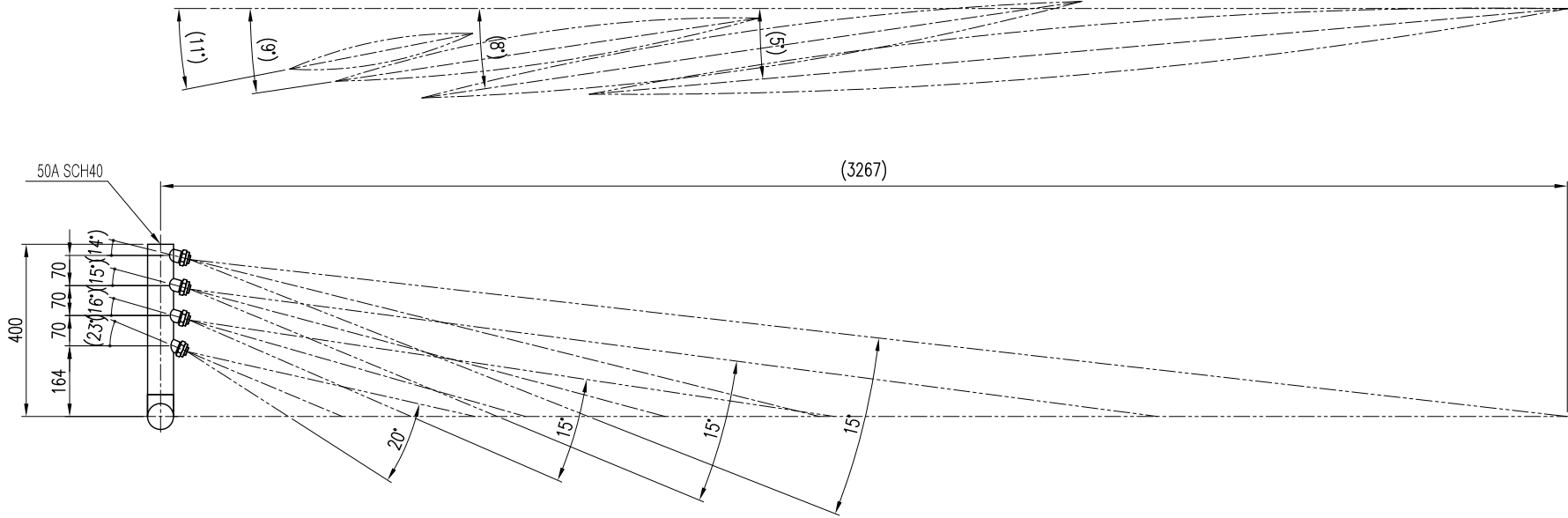

| | | | | |
|------|----------------|----------|------|---------|
| 5 | 50A ELBOW | SUS304 | 1 | |
| 4 | RETAINERRING | SUS303 | 4 | |
| 3 | BODY | SUS304 | 4 | |
| 2 | TIP | SUS303 | 4 | |
| 1 | PIPE 50A SCH40 | SUS304 | 1 | |
| ITEM | COMPONENT | MATERIAL | Q'TY | REMARKS |

| | | | |
|-------|-----------------|------------|--|
| DESC. | KHD163577-SS-01 | CUSTOMER : | |
| | SPRAY HEADER | | |

| | | | |
|---------|---------|----------|----------------|
| APP BY. | CH BY. | DES BY. | PRODUCT NAME : |
| B.S.KIM | J.M.LEE | J.H.JUNG | |

| | | |
|--|--------------|---------------|
| | SCALE : | CREATE DATE : |
| | 1:1 | 2017.08.14 |
| | DWG. NO. : | |
| | 56163-577-C2 | |

지시외 용접치수 절삭가공치수의 지시외 일반치수 허용차 (KS B ISO2768-1 중급)

| | | | | | | |
|-----------|-------------------------------|----------------|---------------|----------------|------------------|-------------------|
| | 구 분 | 0.5 이상 3 이하 | 3 을초과 6 이하 | 6 을초과 30 이하 | 30 을초과 120 이하 | 120 을초과 400 이하 |
| | 허용 차 | ±0.1 | ±0.1 | ±0.2 | ±0.3 | ±0.5 |
| 지시외 모서리부분 | SURFACE ROUGHNESS (KS B 0617) | | | | | |
| C= R= | 다듬질기호 | ~ | ▽ | ▽▽ | ▽▽▽ | ▽▽▽▽ |
| | Rmax | | 100S | 25S | 6.3S | 0.8S |

| | |
|-----------------------|----------------------|
| SPECIFICATION | |
| PRESSURE | SPRAY ANGLE (±7°) |
| (XXX) | (XXX)~(XXX)~(XXX) |
| (kg/cm ²) | (XXX)~(XXX)~(XXX) |
| | CAPACITY (ℓ/min ±7%) |

| CHECK LIST | | | | | ECO NO. | DATE | REVISION & DESCRIPTION | REVWED | CHECKED |
|------------|-----------|-----------|----------|--|---------|------|------------------------|--------|---------|
| LENGTH | ITEM NAME | CONNECTOR | CAPACITY | | | | | | |
| WIDTH | MARKING | ORIFICE | COMMENT | | | | | | |

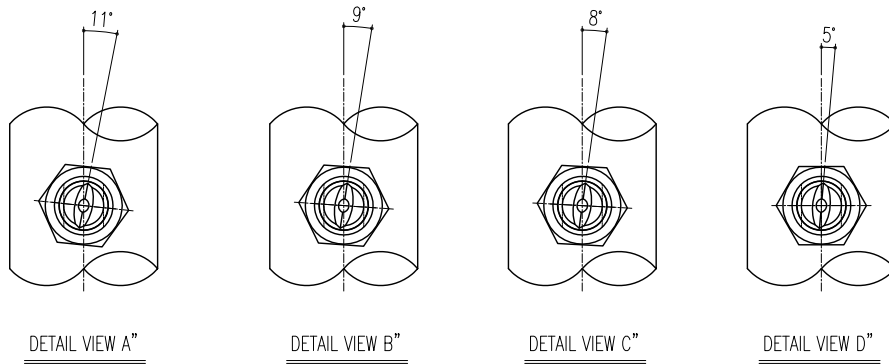
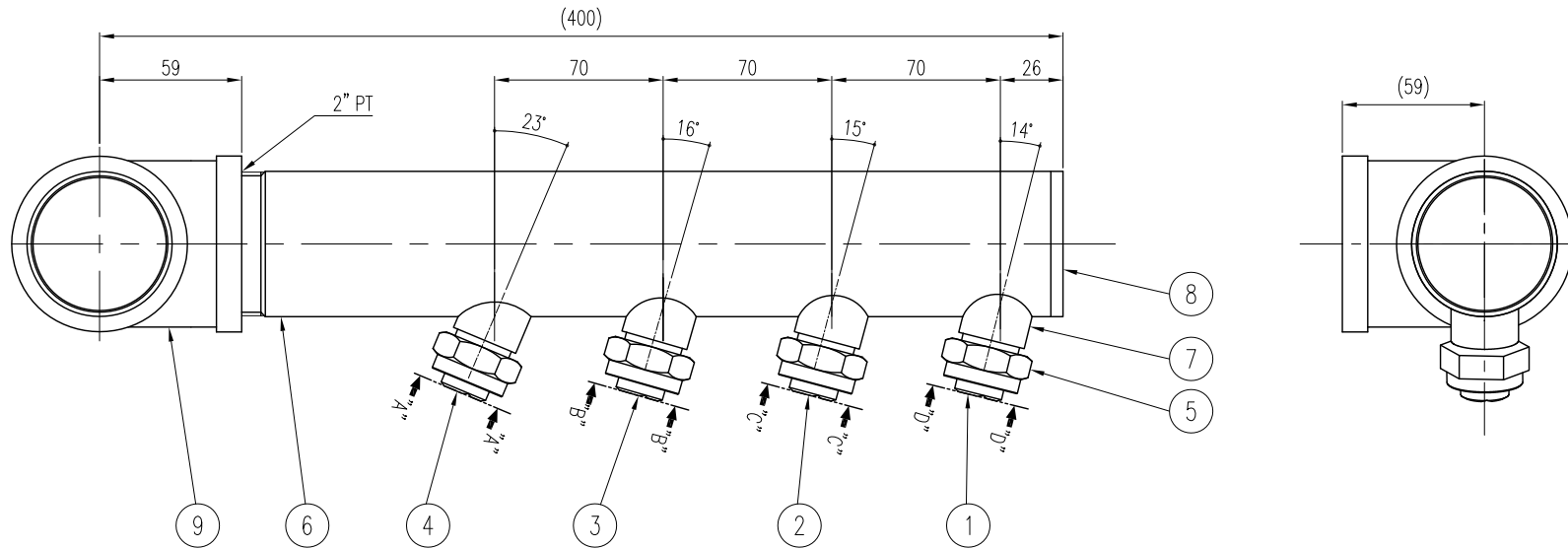

| | | | | |
|-------|---------------------------------|------------|------|---------|
| 9 | 50A SCREW ELBOW | SUS304 | 1 | |
| 8 | END PLATE | SUS304 | 1 | |
| 7 | BODY | SUS304 | 4 | |
| 6 | PIPE 50A SCH40 | SUS304 | 1 | |
| 5 | RETAINER RING(KRT3/4-167105-SS) | SUS303 | 4 | |
| 4 | TIP(KDTP18897-2080-SS-02) | SUS303 | 1 | |
| 3 | TIP(KDTP18897-1580-SS-07) | SUS303 | 1 | |
| 2 | TIP(KDTP18897-1580-SS-06) | SUS303 | 1 | |
| 1 | TIP(KDTP18897-1580-SS-05) | SUS303 | 1 | |
| ITEM | COMPONENT | MATERIAL | Q'TY | REMARKS |
| DESC. | KHD163577-SS-01 | CUSTOMER : | | |
| | SPRAY HEADER | | | |

지시의 용접치수 절삭가공치수의 지시와 일반치수 허용차 (KS B ISO2768-1 중급)

| 구분 | 0.5 이상 3 이하 | 3 초과 6 이하 | 6 초과 30 이하 | 30 초과 120 이하 | 120 초과 400 이하 |
|----|----------------|--------------|---------------|-----------------|------------------|
| | 허용차 | ±0.1 | ±0.1 | ±0.2 | ±0.3 |

| 지시와 모서리부분 | | SURFACE ROUGHNESS (KS B 0617) | | | | | |
|-----------|-------|-------------------------------|------|-----|------|------|--|
| C= | 다듬질기호 | ~ | ▽ | ▽▽ | ▽▽▽ | ▽▽▽▽ | |
| R= | Rmax | | 100S | 25S | 6.3S | 0.8S | |

SPECIFICATION

| | |
|--|----------------------|
| PRESSURE (XXX) (kg/cm ²) | SPRAY ANGLE (±7°) |
| | (XXX)~(XXX)~(XXX) |
| | (XXX)~(XXX)~(XXX) |
| | CAPACITY (ℓ/min ±7%) |

| | | |
|--------------------|-------------------|---------------------|
| APP BY. J.M.LEE | CH BY. J.H.YOU | DES BY. J.H.JUNG |
|--------------------|-------------------|---------------------|

Spraying Systems Co., Korea
 Export in Spray Technology

| | | |
|----------------|-------------|-------------------------|
| PRODUCT NAME : | SCALE : 1:1 | CREATE DATE : |
| | THIRD ANGLE | DWG. NO. : 56163-577-A2 |