

Manufacturer of Steel Bars Saves More Than US\$800,000 Using New Spray Cooling System

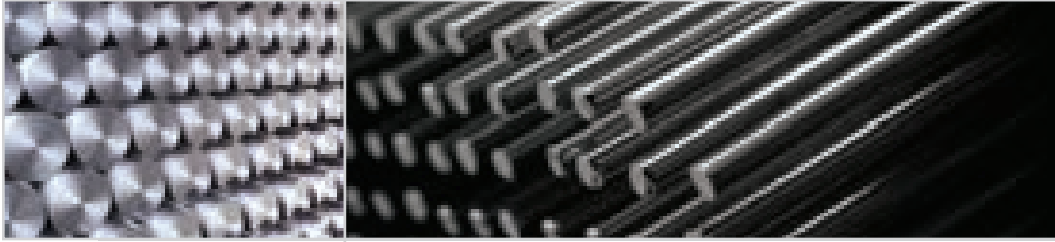

Problem:

A manufacturer of engineered steel products uses a surface-riding probe to measure defects on steel bars. High production speeds and the high rotational speed used for the surface testing generate a great deal of friction, which was causing the probes to overheat. When this problem occurred, the dwell time between steel bars had to be increased, resulting in reduced production.

A simple spray cooling system using a water reservoir and siphon-fed air atomizing nozzles was being used to keep the probes cool, but because the nozzles plugged frequently, the system was ineffective. The system also lacked the ability to adjust for seasonal temperature changes, creating even greater problems during the summer when outdoor temperatures were higher.

Solution:

Spraying Systems Co.'s solution uses an AutoJet® Model 1550 Modular Spray System and air atomizing nozzle. A proximity sensor triggers the spray nozzle at the start and end of each bar. The 1/4JAUPMCO air atomizing nozzle provides a fine mist which cools the bars with almost 100% evaporation of the water. The nozzle is equipped with a clean-out needle to prevent clogging of the orifice. The system also allows easy flow rate adjustment to account for ambient temperature changes throughout the year.

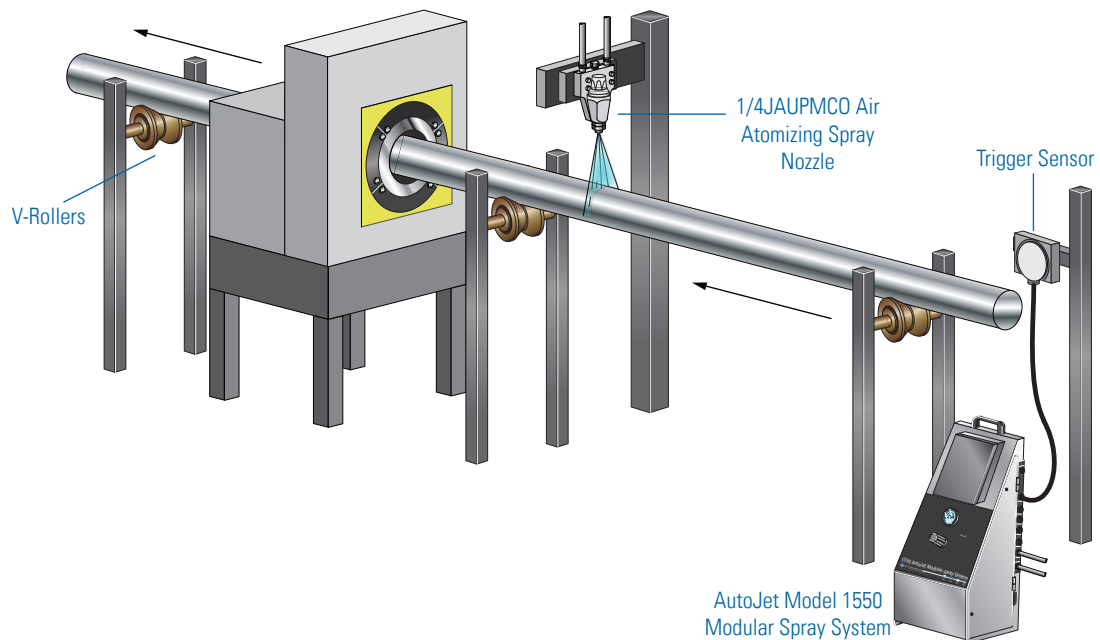

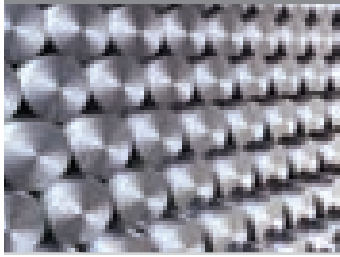

Manufacturer of Steel Bars Saves More Than US\$800,000 Using New Spray Cooling System – Continued

Results:

The AutoJet® Modular Spray System and 1/4JAUPMCO nozzle have enabled the mill to maintain the temperature of the probes well below the maximum allowable temperature even when the ambient temperature is high. Production has increased by more than 15% during the summer months. The annual value of the additional output on two production lines is estimated at more than US\$800,000, resulting in a payback of less than one week on the new spray equipment.

A CLOSER LOOK AT THE SYSTEM

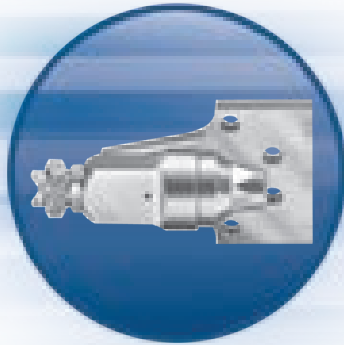

A 1/4JAUPMCO automatic air atomizing nozzle provides the necessary cooling with nearly complete evaporation. The nozzle features a plate-mount design and a clean-out needle to prevent plugging.

AutoJet Model 1550 Modular Spray System allows easy flow rate adjustment and automatic regulation of the liquid pressure and the atomizing air pressure. Consistent water application on the steel bars provides the necessary cooling.



Spraying Systems Co.®
Experts in Spray Technology

North Avenue and Schmale Road, P.O. Box 7900, Wheaton, IL 60187-7901 USA

Tel: 1.800.95.SPRAY Intl. Tel: 1.630.665.5000

Fax: 1.888.95.SPRAY Intl. Fax: 1.630.260.0842

www.spray.com



Case Study No. 150A Printed in the U.S.A. ©Spraying Systems Co. 2014