

ECO NO.	DATE	REVISION & DESCRIPTION	REVWED	CHECKED
△	2018.08.07	B1/4MEG-SS 6503->HB1/4U-SS9510, FITTING 변경	J.H.JUNG	J.H.YOU
△	2018.08.09	구조 변경	J.H.JUNG	J.H.YOU
△	2019.01.10	구조 변경 & 1950->2350 길이 변경	J.H.JUNG	J.H.YOU

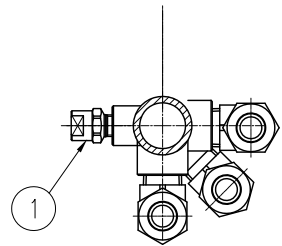
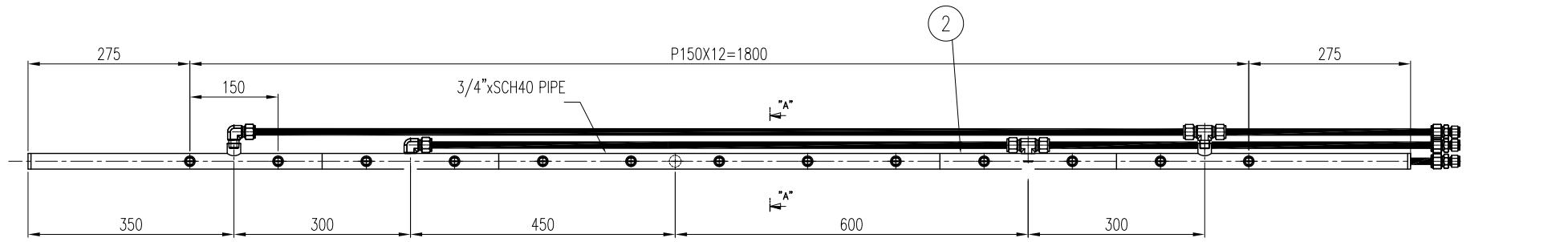
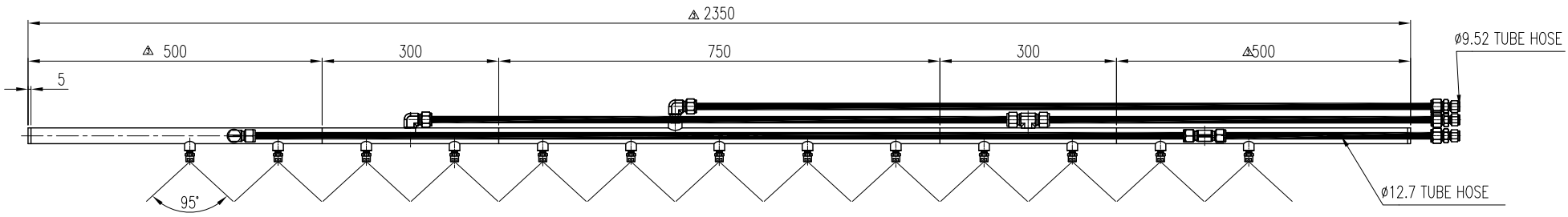

SECTION A'-A'  
SCALE 3:1

2	PIPE(3/4"xSCH40)	SUS304	1	
1	△ NOZZLE(HB1/4U-SS9510)	SUS303	13	IMPORT
ITEM	COMPONENT	MATERIAL	Q'TY	REMARKS
DESC.	KHD163530-SS WET유 SPRAY HEADER	CUSTOMER : 광) ICGL		
APP BY.	CH BY.	DES BY.	PRODUCT NAME :	
J.H.JUNG	J.H.YOU	J.H.JUNG		

지시의 용접치수	절삭가공치수의 지시와 일반치수 허용차 (KS B ISO2768-1 중급)						SPECIFICATION	
	구 분	0.5 이상 3 이하	3 을초과 6 이하	6 을초과 30 이하	30 을초과 120 이하	120 을초과 400 이하	PRESSURE	SPRAY ANGLE (±7°)
	허용 차	±0.1	±0.1	±0.2	±0.3	±0.5		(XXX)~(XXX)~(XXX)
지시외 모서리부분	SURFACE ROUGHNESS (KS B 0617)						(XXX) (kg/cm <sup>2</sup> )	(XXX)~(XXX)~(XXX)
C= R=	다듬질기호	~	▽	▽▽	▽▽▽	▽▽▽▽		CAPACITY (ℓ/min ±7%)
	Rmax		100S	25S	6.3S	0.8S		

**Spraying Systems Co., Korea**  
Export in Spray Technology

SCALE : 1:1	CREATE DATE : 2019.01.08
THIRD ANGLE	DWG. NO. : 56163-530-C1

ECO NO.	DATE	REVISION & DESCRIPTION	REVWED	CHECKED

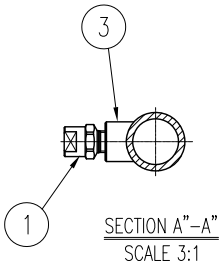
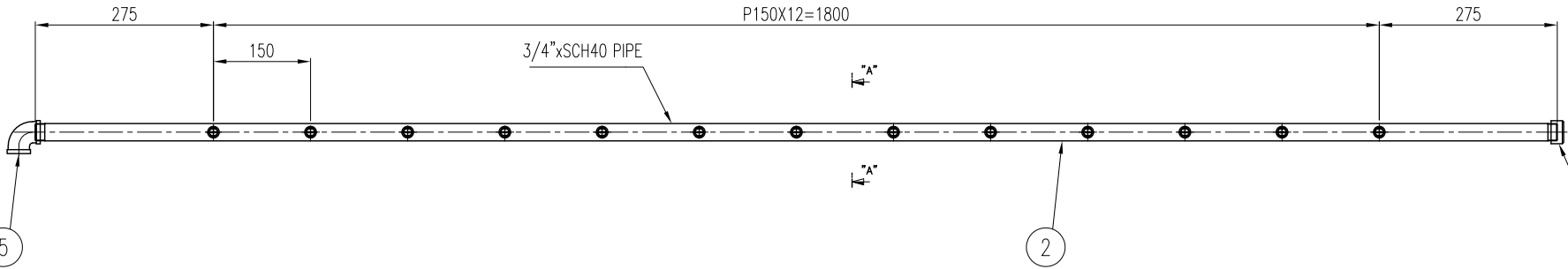
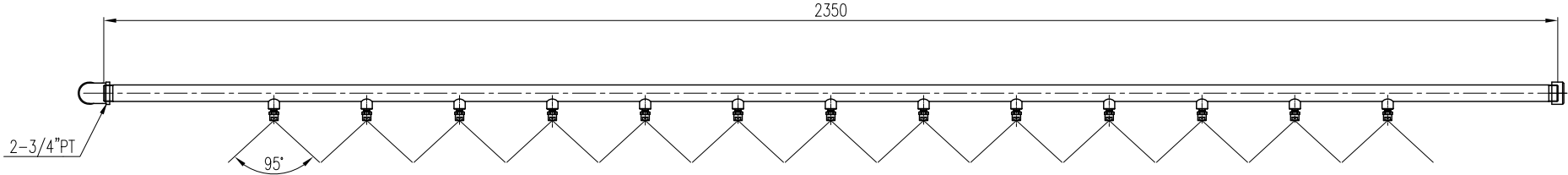

5	ELBOW(20A)	SUS304	1	PUR
4	END CAP(20A)	SUS304	1	PUR
3	SOCKET	SUS304	13	
2	PIPE(3/4"xSCH40)	SUS304	1	
1	NOZZLE(HB1/4U-SS9510)	SUS303	13	IMPORT
ITEM	COMPONENT	MATERIAL	Q'TY	REMARKS

DESC.	KHD163647-SS	CUSTOMER :	광) 1CGL (2)
APP BY.	J.M.LEE	CH BY.	J.H.YOU
DES BY.	J.H.JUNG	PRODUCT NAME :	

SCALE :	1:1	CREATE DATE :	2019.01.10
THIRD ANGLE		DWG. NO. :	56163-647-C1

지시의 용접치수	절삭가공치수의 지시와 일반치수 허용차 (KS B ISO2768-1 중급)					
	구 분	0.5 이상 3 이하	3 을초과 6 이하	6 을초과 30 이하	30 을초과 120 이하	120 을초과 400 이하
	허용 차	±0.1	±0.1	±0.2	±0.3	±0.5
지시와 모서리부분	SURFACE ROUGHNESS (KS B 0617)					
C=	다듬질기호	~	▽	▽▽	▽▽▽	▽▽▽▽
R=	Rmax		100S	25S	6.3S	0.8S

SPECIFICATION	
PRESSURE	SPRAY ANGLE (±7°)
(XXX)	(XXX)~(XXX)~(XXX)
(kg/cm²)	(XXX)~(XXX)~(XXX)
	CAPACITY (ℓ/min ±7%)

**Spraying Systems Co., Korea**  
Export in Spray Technology

ECO NO.	DATE	REVISION & DESCRIPTION	REVISED	CHECKED

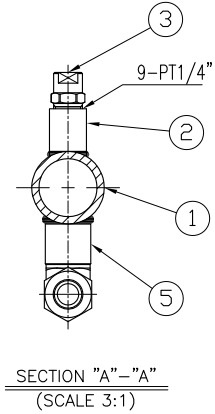
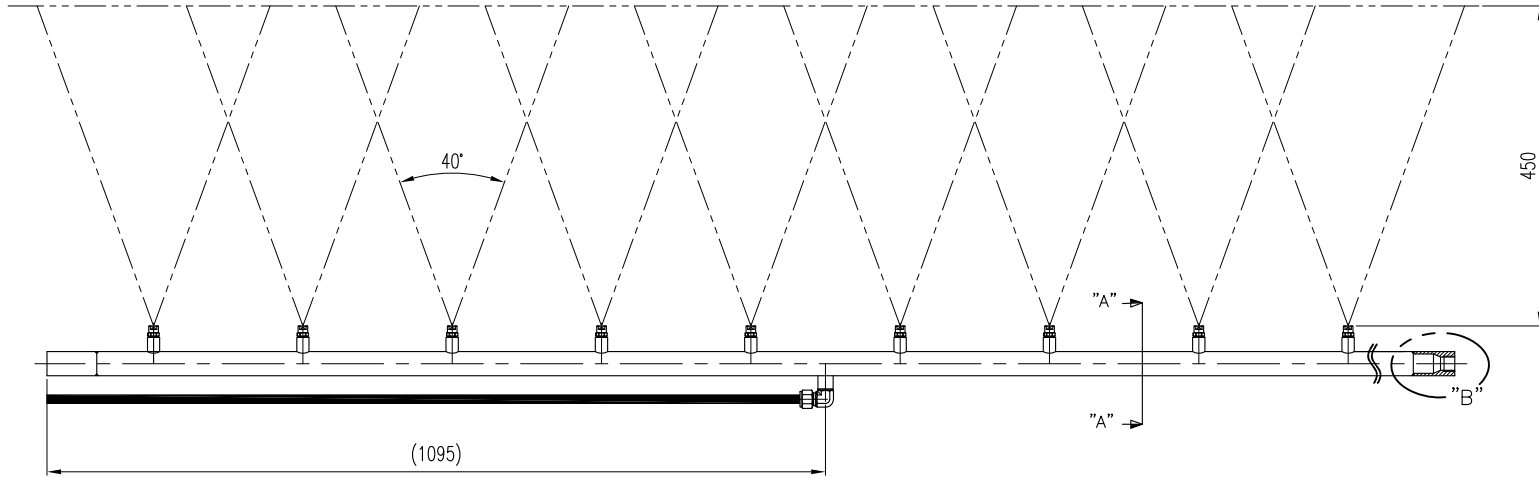
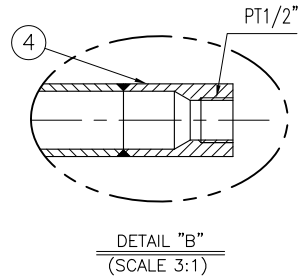
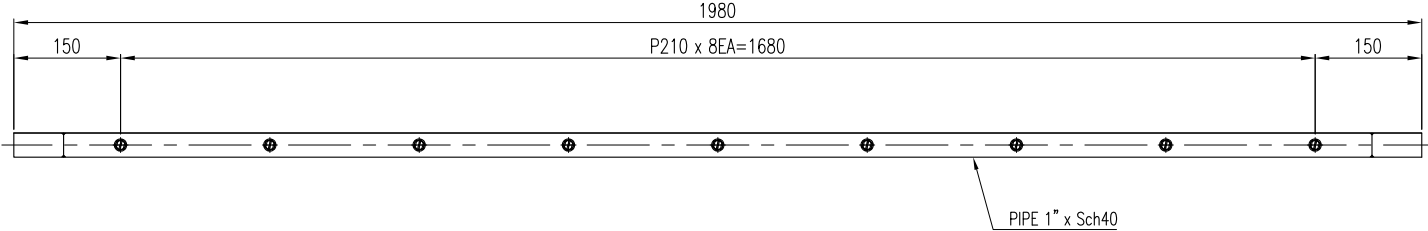

5	PIPE BUTT WEID ELBOW(UWBE-0808P)	SUS304	1	
4	NIPPLE	SUS304	2	
3	NOZZLE(KB1/4MEG-SS 4003)	SUS303	9	
2	SOCKET	SUS304	9	
1	PIPE(1" x SCH 40)	SUS304	1	
ITEM	COMPONENT	MATERIAL	Q'TY	REMARKS

DESC.	KHD163540-304SS WE T-YU SPRAY HEADER	CUSTOMER : 광 2,4CGL
-------	---	------------------------

APP BY.	CH BY.	DES BY.	PRODUCT NAME :
J.M.LEE	J.H.YOU	Y.M.KO	-

	SCALE :	CREATE DATE :
	1:10	2016.11.08
	THIRD ANGLE	DWG. NO. :
		56163-540-C1

지시외 용접치수	절삭가공치수의 지시외 일반치수 허용차 (KS B ISO2768-1 중급)					
	구 분	0.5 이상 3 이하	3 을초과 6 이하	6 을초과 30 이하	30 을초과 120 이하	120 을초과 400 이하
	허 용 차	±0.1	±0.1	±0.2	±0.3	±0.5
지시외 모서리부분	SURFACE ROUGHNESS (KS B 0617)					
C=	다듬질기호	~	▽	▽▽	▽▽▽	▽▽▽▽
R=	Rmax		100S	25S	6.3S	0.8S

SPECIFICATION	
PRESSURE	SPRAY ANGLE (±7°)
(XXX)	(XXX)~(XXX)~(XXX)
(kg/cm <sup>2</sup> )	(XXX)~(XXX)~(XXX)
	CAPACITY (ℓ/min ±7%)

CHECK LIST

ECO NO.	DATE	REVISION & DESCRIPTION	REVWED	CHECKED

LENGTH	ITEM NAME	CONNECTOR	CAPACITY
WIDTH	MARKING	ORIFICE	COMMENT

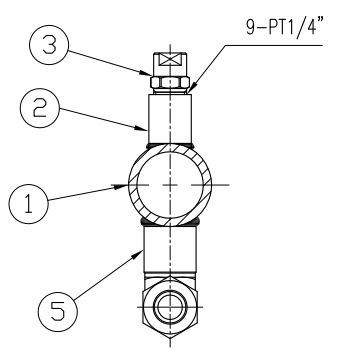
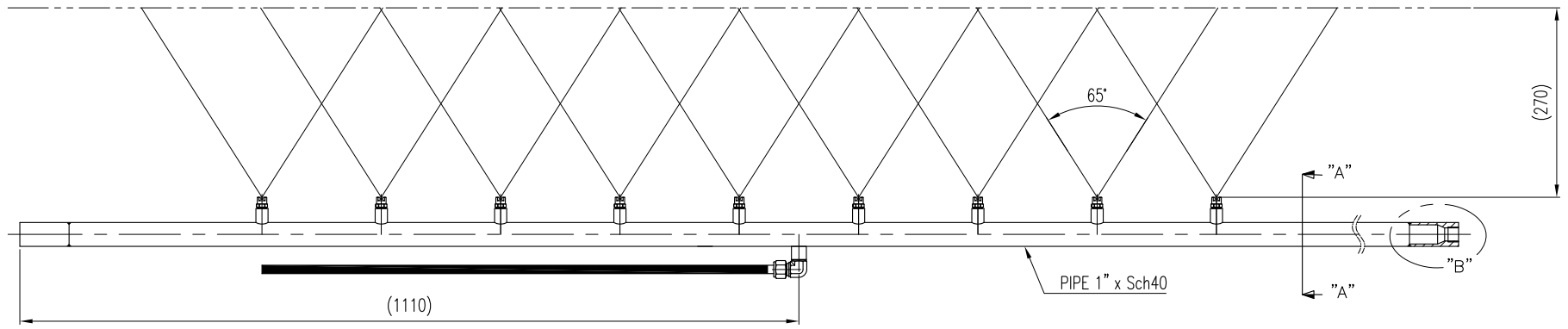
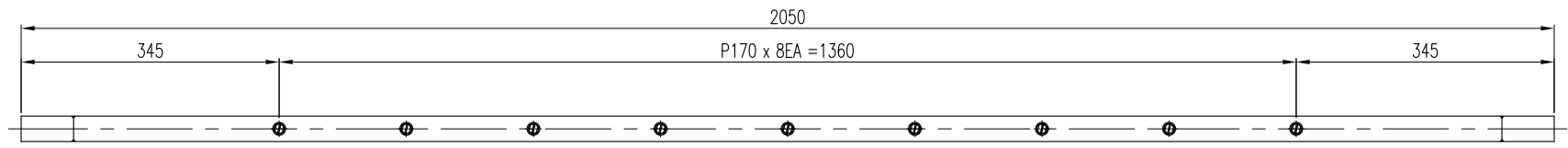

SECTION "A"- "A"  
(SCALE 3:1)

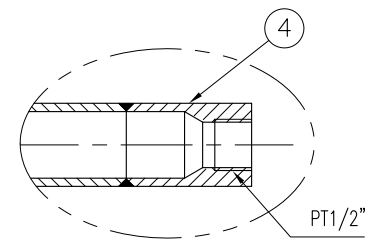

DETAIL "B"  
(SCALE 3:1)

ITEM	COMPONENT	MATERIAL	Q'TY	REMARKS
5	PIPE BUTT WEID ELBOW(UWBE-0808P)	SUS304	1	
4	NIPPLE	SUS304	2	
3	NOZZLE(KB1/4MEG-304SS 6503)	SUS304	9	
2	SOCKET	SUS304	9	
1	PIPE(1" x SCH 40)	SUS304	1	

DESC.	KHD163534-304SS WE' T 유 SPRAY HEADER	CUSTOMER :	광) 3CGL
-------	---	------------	---------

APP BY.	CH BY.	DES BY.	PRODUCT NAME :
J.M.LEE	J.H.YOU	Y.M.KO	-

<p>Spraying Systems Co., Korea Export in Spray Technology</p>	SCALE :	CREATE DATE :
	1:9	2016.10.20
	DWG. NO. :	
	56163-534-C1	

지시의 용접치수	절삭가공치수의 지시와 일반치수 허용차 (KS B ISO2768-1 중급)					
	구 분	0.5 이상 3 이하	3 을초과 6 이하	6 을초과 30 이하	30 을초과 120 이하	120 을초과 400 이하
	허용 차	±0.1	±0.1	±0.2	±0.3	±0.5
지시외 모서리부분	SURFACE ROUGHNESS (KS B 0617)					
	다듬질기호	~	▽	▽▽	▽▽▽	▽▽▽▽
	Rmax		100S	25S	6.3S	0.8S

PRESSURE (XXX) (kg/cm <sup>2</sup> )	SPECIFICATION
	SPRAY ANGLE (±7°) (XXX)~(XXX)~(XXX)
	(XXX)~(XXX)~(XXX) CAPACITY (ℓ/min ±7%)

CHECK LIST					ECO NO.	DATE	REVISION & DESCRIPTION	REVISED	CHECKED
LENGTH	ITEM NAME	CONNECTOR	CAPACITY		△				
WIDTH	MARKING	ORIFICE	COMMENT		△				

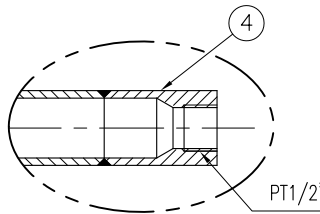
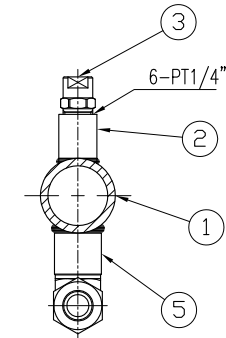
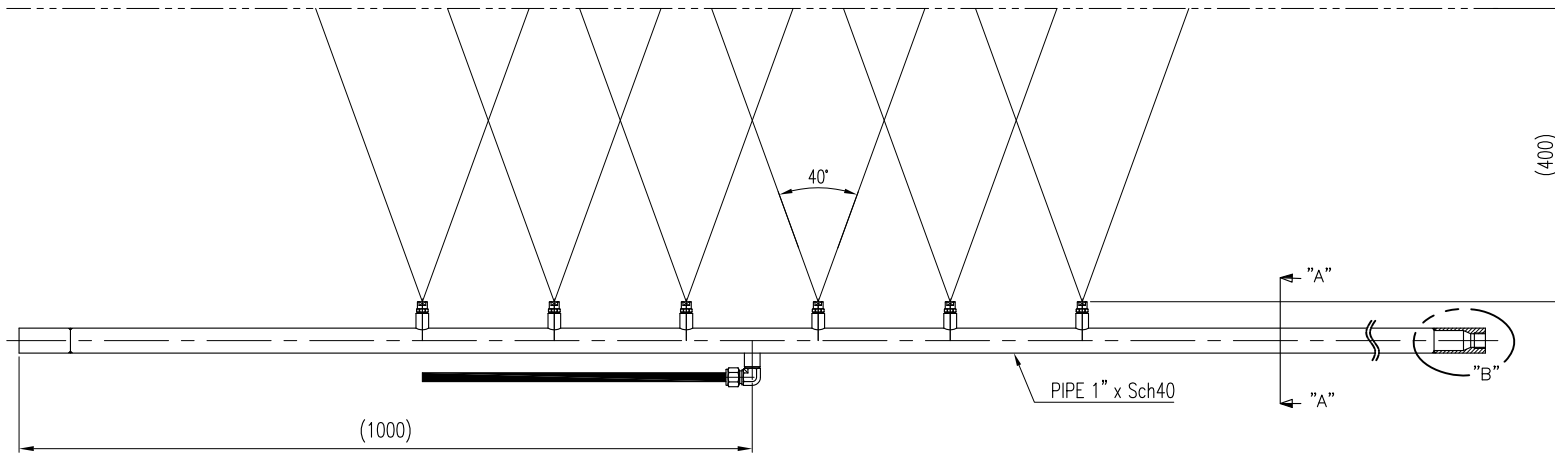
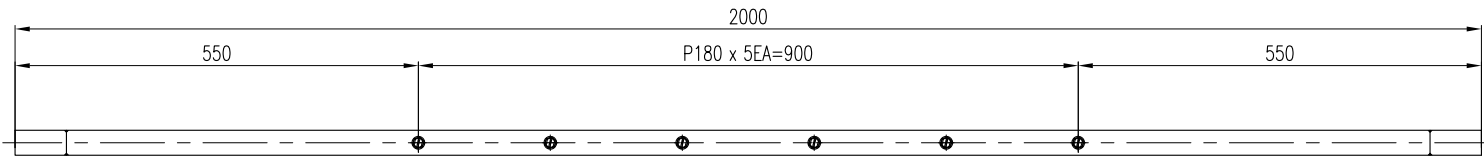

DETAIL "B"  
(SCALE 3:1)

5	PIPE BUTT WEID ELBOW(UWBE-0808P)	SUS304	1	
4	NIPPLE	SUS304	2	
3	NOZZLE(KB1/4MEG-304SS 4003)	SUS304	6	
2	SOCKET	SUS304	6	
1	PIPE(1" x SCH 40)	SUS304	1	
ITEM	COMPONENT	MATERIAL	Q'TY	REMARKS
DESC.	KHD163535-304SS		CUSTOMER : 광) 3CGL	
	WET-유 SPRAY HEADER			

지시외 용접치수 절삭가공치수의 지시외 일반치수 허용차 (KS B ISO2768-1 중급)

구분	0.5 이상 3 이하	3 초과 6 이하	6 초과 30 이하	30 초과 120 이하	120 초과 400 이하
허용차	±0.1	±0.1	±0.2	±0.3	±0.5

지시외 모서리부분		SURFACE ROUGHNESS (KS B 0617)					
C=	다듬질기호	~	▽	▽▽	▽▽▽	▽▽▽▽	
R=	Rmax		100S	25S	6.3S	0.8S	

SPECIFICATION	
PRESSURE	SPRAY ANGLE (±7°) (XXX)~(XXX)~(XXX)
(XXX) (kg/cm <sup>2</sup> )	(XXX)~(XXX)~(XXX) CAPACITY (ℓ/min ±7%)

APP BY: J.M.LEE CH BY: J.H.YOU DES BY: Y.M.KO

PRODUCT NAME : -

SCALE : 1:10 CREATE DATE : 2016.10.20

THIRD ANGLE DWG. NO. : 56163-535-C1

**Spraying Systems Co., Korea**  
Export in Spray Technology

CHECK LIST

ECO NO.	DATE	REVISION & DESCRIPTION	REVISED	CHECKED

LENGTH	ITEM NAME	CONNECTOR	CAPACITY
WIDTH	MARKING	ORIFICE	COMMENT

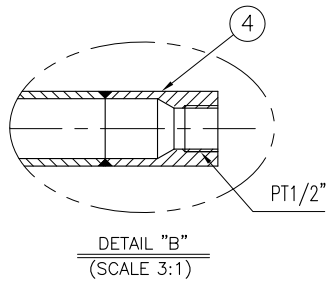
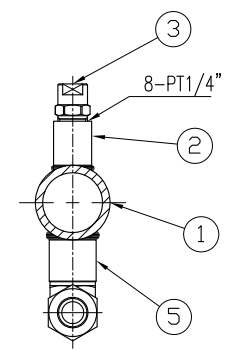
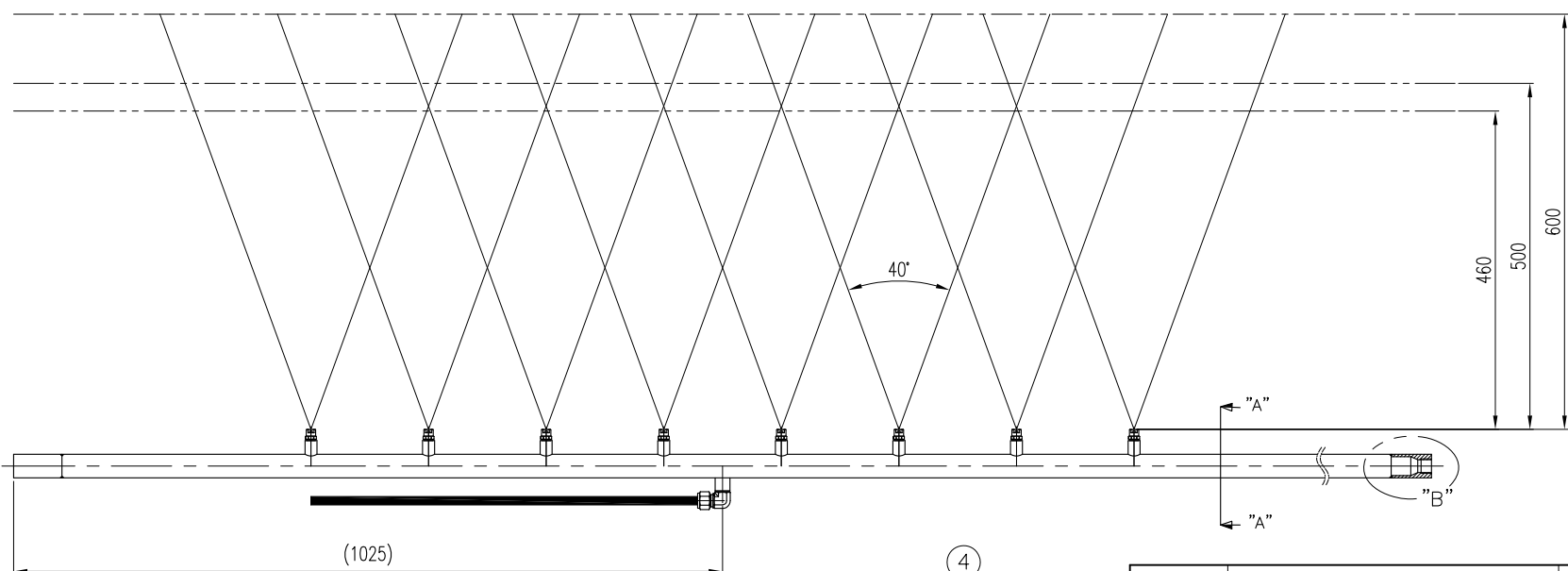
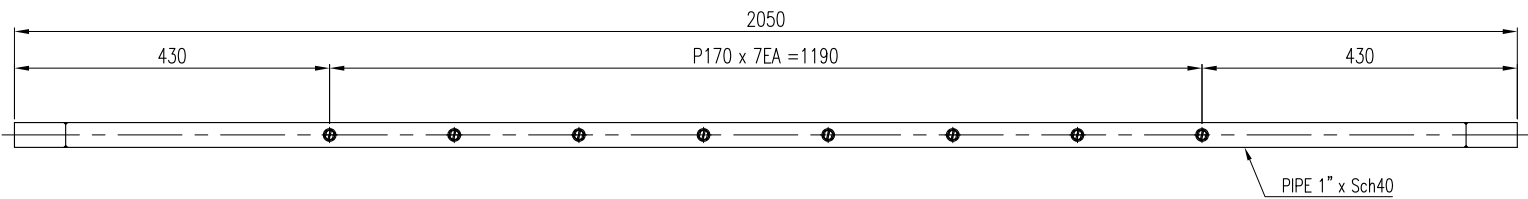

ITEM	COMPONENT	MATERIAL	Q'TY	REMARKS
5	PIPE BUTT WEID ELBOW(UWBE-0808P)	SUS304	1	
4	NIPPLE	SUS304	2	
3	NOZZLE(KB1/4MEG-304SS 4003)	SUS304	8	
2	SOCKET	SUS304	8	
1	PIPE(1" x SCH 40)	SUS304	1	

DESC.	KHD163538-304SS WET 유 SPRAY HEADER	CUSTOMER :	광) 3CGL	
APP BY.	CH BY.	DES BY.	PRODUCT NAME :	
J.M.LEE	J.H.YOU	Y.M.KO	-	

지시의 용접치수	절삭가공치수의 지시와 일반치수 허용차 (KS B ISO2768-1 중급)					
	구 분	0.5 이상 3 이하	3 을초과 6 이하	6 을초과 30 이하	30 을초과 120 이하	120 을초과 400 이하
	허용 차	±0.1	±0.1	±0.2	±0.3	±0.5
지시외 모서리부분	SURFACE ROUGHNESS (KS B 0617)					
	다듬질기호	~	▽	▽▽	▽▽▽	▽▽▽▽
	Rmax		100S	25S	6.3S	0.8S

PRESSURE (XXX) (kg/cm <sup>2</sup> )	SPRAY ANGLE (±7°)	(XXX)~(XXX)~(XXX)
	(XXX)~(XXX)~(XXX)	
	CAPACITY (ℓ/min ±7%)	

**Spraying Systems Co., Korea**  
Export in Spray Technology

SCALE :	CREATE DATE :
1:10	2016.10.20
THIRD ANGLE	DWG. NO. :
	56163-538-C1

CHECK LIST

ECO NO.	DATE	REVISION & DESCRIPTION	REVWED	CHECKED

LENGTH	ITEM NAME	CONNECTOR	CAPACITY
WIDTH	MARKING	ORIFICE	COMMENT

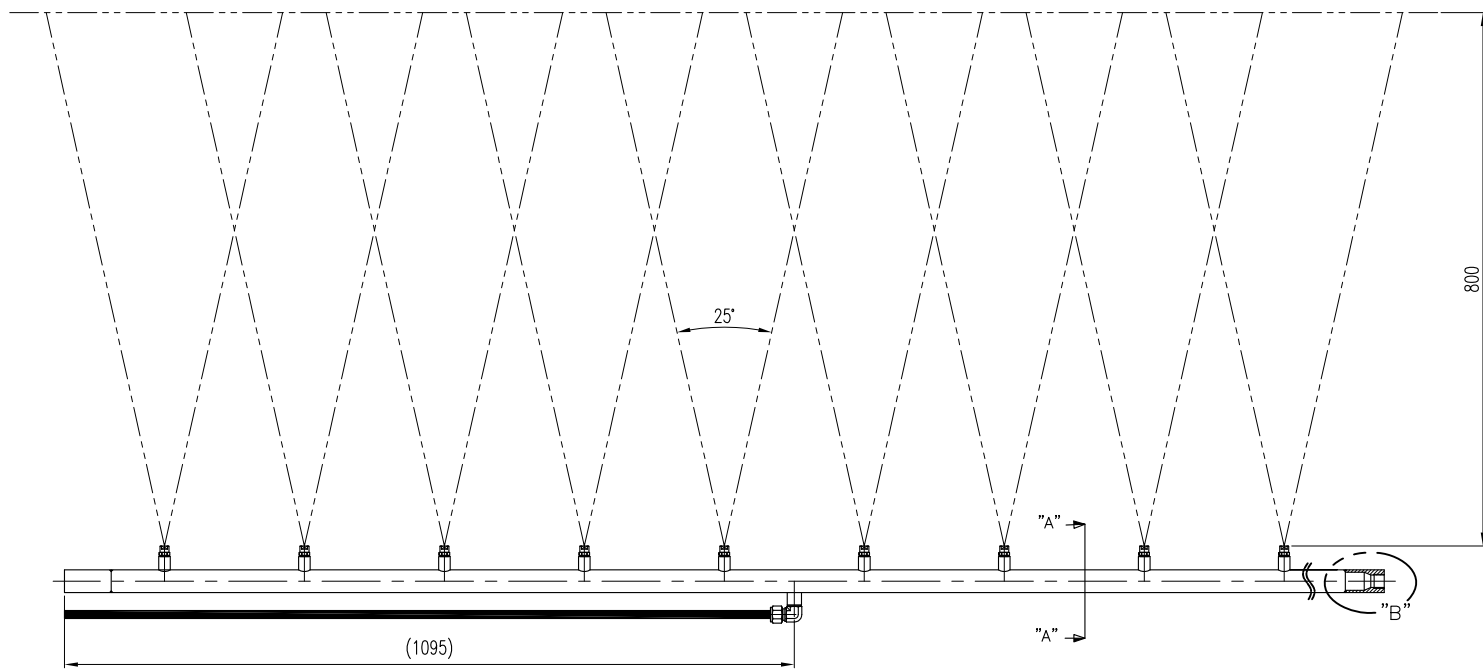
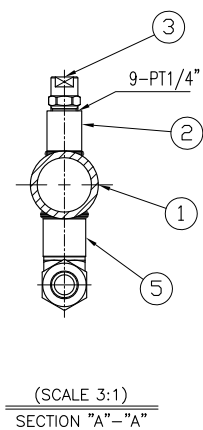
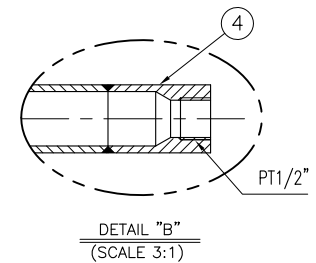
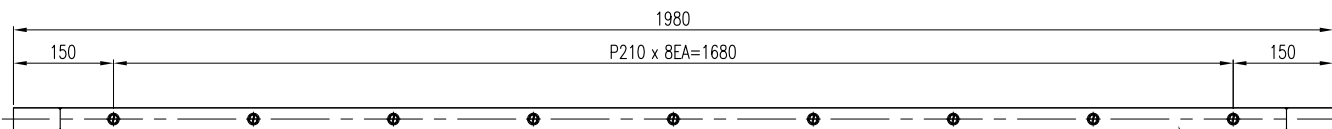

5	PIPE BUTT WEID ELBOW(UWBE-0808P)	SUS304	1		2	SOCKET	SUS304	9	
4	NIPPLE	SUS304	2		1	PIPE(1" x SCH 40)	SUS304	1	
3	NOZZLE(KB1/4MEG-SS 2503)	SUS303	9		ITEM	COMPONENT	MATERIAL	Q'TY	REMARKS
ITEM	COMPONENT	MATERIAL	Q'TY	REMARKS	DESC.	KHD163541-304SS	CUSTOMER : 광) 5,6 CGL		

구분	0.5 이상 3 이하	3 을초과 6 이하	6 을초과 30 이하	30 을초과 120 이하	120 을초과 400 이하
지시의 용접치수	절삭가공치수의 지시와 일반치수 허용차 (KS B ISO2768-1 중급)				
지시의 모서리부분	SURFACE ROUGHNESS (KS B 0617)				
C= R=	다듬질기호	~	▽	▽▽	▽▽▽
	Rmax		100S	25S	6.3S 0.8S

SPECIFICATION	
PRESSURE	(XXX) (kg/cm <sup>2</sup> )
SPRAY ANGLE (±7°)	(XXX)~(XXX)~(XXX)
CAPACITY (ℓ/min ±7%)	(XXX)~(XXX)~(XXX)

APP BY: J.M.LEE    CH BY: J.H.YOU    DES BY: Y.M.KO

PRODUCT NAME : -

SCALE : 1:11    CREATE DATE : 2016.11.08

THIRD ANGLE

DWG. NO. : 56163-541-C1

**Spraying Systems Co., Korea**  
Export in Spray Technology

ECO NO.	DATE	REVISION & DESCRIPTION	REVISED	CHECKED
△				
△				

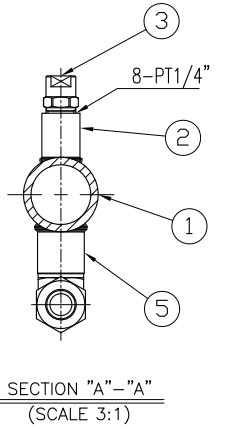
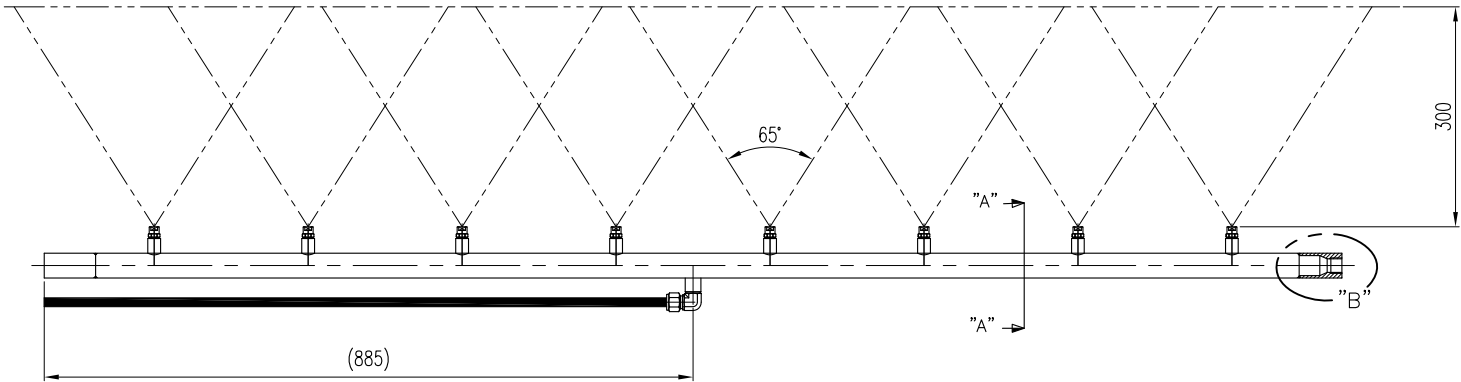
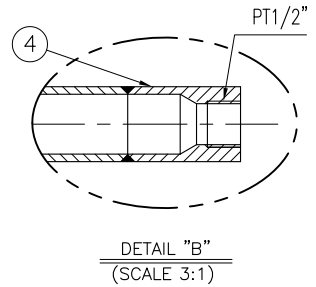
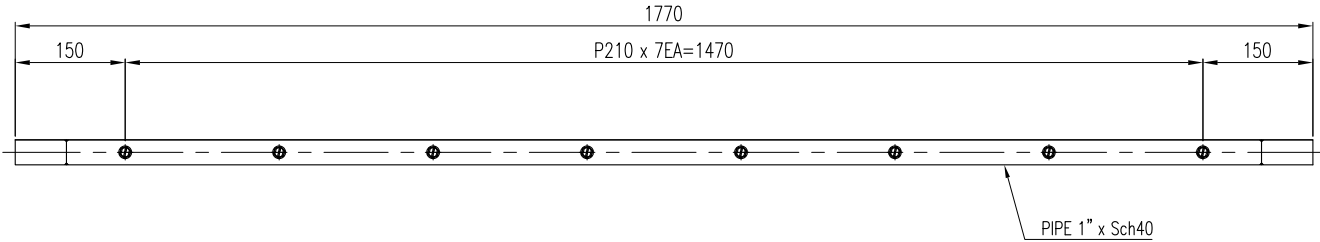

ITEM	COMPONENT	MATERIAL	Q'TY	REMARKS
5	PIPE BUTT WEID ELBOW(UWBE-0808P)	SUS304	1	
4	NIPPLE	SUS304	2	
3	NOZZLE(KB1/4MEG-SS 6503)	SUS303	8	
2	SOCKET	SUS304	8	
1	PIPE(1" x SCH 40)	SUS304	1	

DESC.	KHD163542-304SS WET 유 SPRAY HEADER		CUSTOMER : 광) HCGL	
APP BY.	CH BY.	DES BY.	PRODUCT NAME :	
J.M.LEE	J.H.YOU	Y.M.KO	-	
SCALE :		CREATE DATE :		
1:10		2016.11.08		
THIRD ANGLE		DWG. NO. :		
① ②		56163-542-C1		

지시의 용접치수	절삭가공치수의 지시와 일반치수 허용차 (KS B ISO2768-1 중급)						SPECIFICATION	
	구 분	0.5 이상 3 이하	3 을초과 6 이하	6 을초과 30 이하	30 을초과 120 이하	120 을초과 400 이하	PRESSURE	SPRAY ANGLE (±7°) (XXX)~(XXX)~(XXX)
	허용 차	±0.1	±0.1	±0.2	±0.3	±0.5		
지시와 모서리부분	SURFACE ROUGHNESS (KS B 0617)						(XXX) (kg/cm²)	CAPACITY (ℓ/min ±7%)
C= R=	다듬질기호	~	▽	▽▽	▽▽▽	▽▽▽▽		
	Rmax		100S	25S	6.3S	0.8S		

