



**HIGH-PRESSURE RETRIEVABLE
INJECTORS, RETRIEVAL TOOL
& SERVICE VALVE**



Spraying Systems Co.[®]

Experts in Spray Technology





MINIMIZE DOWNTIME, MAXIMIZE SAFETY WITH HIGH-PRESSURE RETRIEVABLE INJECTORS

WHETHER YOU NEED A RETRIEVABLE INJECTOR OR A SAMPLING QUILL,
TURN TO THE EXPERTS IN SPRAY TECHNOLOGY.

We are uniquely qualified to optimize injection performance because of our expertise in spray characteristics. Coupled with decades of experience with code injector design and fabrication, you'll find unmatched technical expertise and manufacturing capabilities.

- Full line of customizable retrievable injectors and quills
- High-quality code manufacturing in a wide range of materials including specialty alloys
- Dependable delivery and competitive pricing
- Testing services available: visual, liquid penetrant, radiographic, ultrasonic, PMI, ferrite, hardness, hydrostatic
- Proven track record in the oil and gas industry

Our retrievable product line for chemical injection or sampling is designed to eliminate the need to depressurize or divert the process line fluid while retrieving the injector or quill. Access fittings are used in conjunction with our retrieval tool and service valve at working pressures up to 6000 psi (414 bar)*. Spraying Systems Co.'s retrievable injectors, retrieval tool and service valve are interchangeable with industry-standard equipment.

*Maximum working pressure varies based on flange class.

IDEAL FOR:

- Crude and natural gas pipelines
- Refineries
- Import/export and LNG terminals
- Petrochemical plants



PRODUCT LINE OVERVIEW

HIGH-PRESSURE RETRIEVABLE INJECTORS

High-pressure retrievable injectors, also known as high-pressure access fittings, are available with three different styles, connection types and lengths

- Styles: Inline injector, 90° injector, quill
- Connections to process pipe: 2" NPS flange, weld, threaded connections
- Side tee connections 1/4" to 1" NPS flange, weld or threaded connections for mating to injection/sampling line
- Up to 3/4" NPS flanged connection for quills, inline nozzles, 90° nozzles
- Lengths up to 42" (107 cm) to fit a wide range of pipeline sizes
- Temperature range: 0°F (-18°C) to 400°F (204°C)
- Materials: carbon steel, stainless steel, high-nickel alloys
- Code compliant: ASME®, code B31.3, NACE-MR0175, CRN, PED

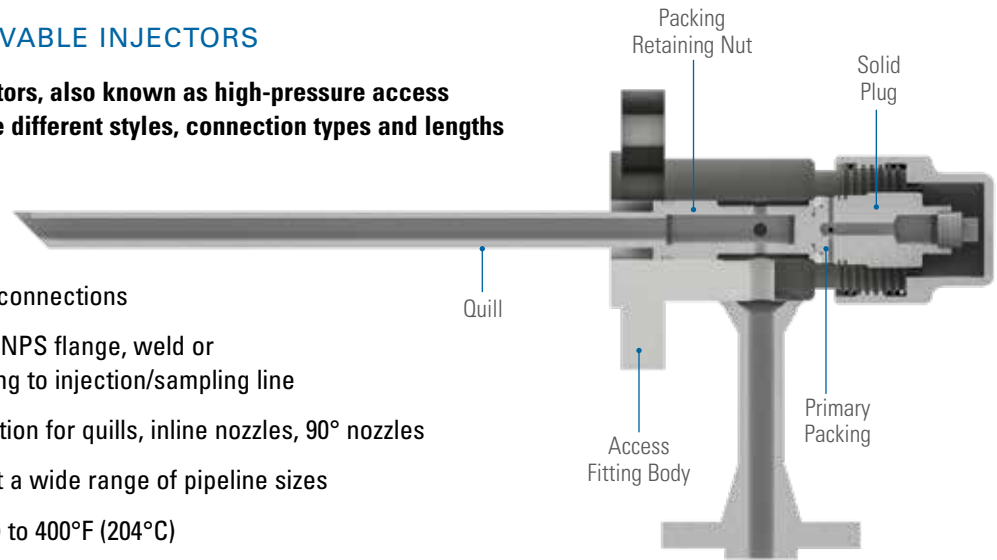

RETRIEVAL TOOL

Retrieval tool for plug removal and closing the valve to maintain line pressure

- Use with multiple injectors
- Compatible with 2" high-pressure access fittings
- Temperature range: 0°F (-18°C) to 200°F (93°C) with standard seal; 0°F (-18°C) to 420°F (215°C) with high temperature seals
- Manufactured to NACE MR-0175 working pressure of 3600 psi (248 bar)

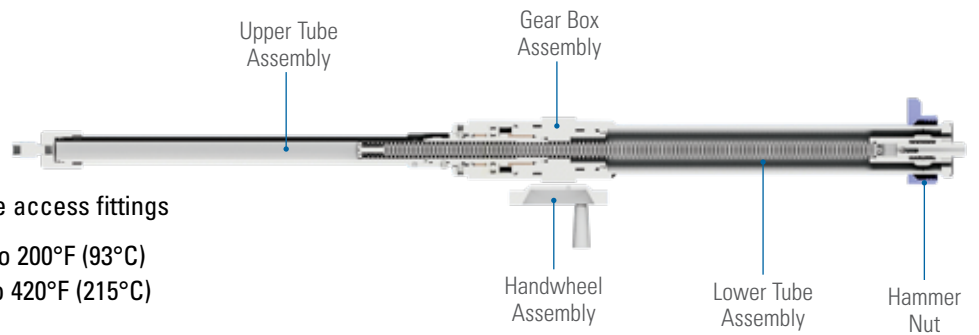

Retrieval tool shown at reduced size

SERVICE VALVE

Service valve is assembled to retrieval tool and attached to access fitting to retrieve, service and reinstall plug with quill/injector all without system shutdown

- Service valve open – system pressure in retrieval tool is equalized; plug with quill/injector can be retrieved
- Service valve closed – system pressure in retrieval tool discharged; plug with quill/injector can be serviced
- NACE MR-0175 compliant, working pressure of 3600 psi (248 bar)
- Standard temperature valve: 0°F (-18°C) to 200°F (93°C)

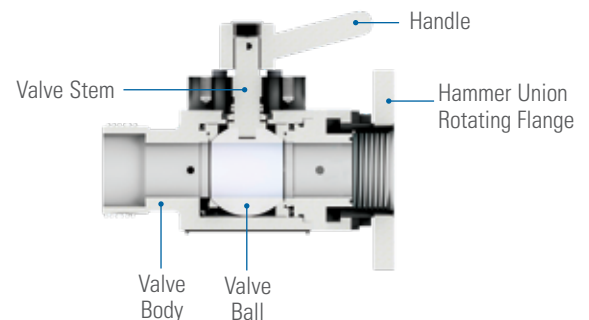

ORDERING INFORMATION

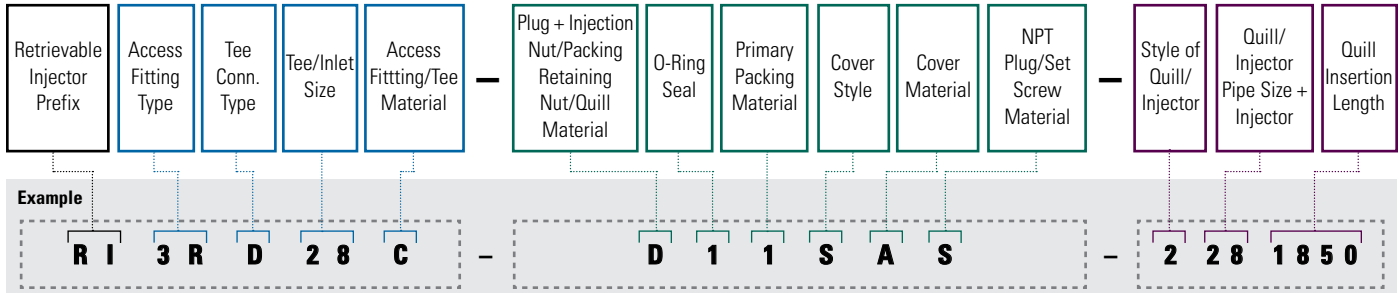

ACCESS FITTING TYPE	
Code	Description
PT	NPT
FW	Flare Weld
SW	Male Socket Weld
4B	Butt Weld sch 40
8B	Butt Weld sch 80
1B	Butt Weld sch 160
XB	Butt Weld sch xxs
1R	Class 150 RF Flange
3R	Class 300 RF Flange
6R	Class 400/600 RF Flange
9R	Class 900/1500 RF Flange
2R	Class 2500 RF Flange
1J	Class 150 RTJ Flange
3J	Class 300 RTJ Flange
6J	Class 400/600 RTJ Flange
9J	Class 900/1500 RTJ Flange
2J	Class 2500 RTJ Flange
1F	Class 150 FF Flange
3F	Class 300 FF Flange
6F	Class 400/600 FF Flange
9F	Class 900/1500 FF Flange
2F	Class 2500 FF Flange
2A	2-1/16 API RJ Flange #2000
5A	2-1/16 API RJ Flange #3000/5000
1A	2-1/16 API RJ Flange #10000

TEE CONNECTION TYPE/CLASS	
Code	Description
A	NPT
B	Socket Weld
C	Class 150 RF Flange*
D	Class 300 RF Flange*
E	Class 400/600 RF Flange*
F	Class 900/1500 RF Flange*
G	Class 2500 RF Flange*
H	Class 150 RTJ Flange*
I	Class 300 RTJ Flange*
J	Class 400/600 RTJ Flange*
K	Class 900/1500 RTJ Flange*
L	Class 2500 RTJ Flange*
M	Class 150 FF Flange*
N	Class 300 FF Flange*
O	Class 400/600 FF Flange*
P	Class 900/1500 FF Flange*
Q	Class 2500 FF Flange*

* Not available in 1/4"

TEE/INLET SIZE SCH	
Code	Description
4S	1/4***
8S	3/8***
2S	1/2***
3S	3/4***
1S	1***
48	1/4" sch 80
46	1/4" sch 160
4X	1/4" sch xxs
88	3/8" sch 80
86	3/8" sch 160
8X	3/8" sch xxs
28	1/2" sch 80
26	1/2" sch 160
2X	1/2" sch xxs
38	3/4" sch 80
36	3/4" sch 160
3X	3/4" sch xxs
18	1" sch 80
16	1" sch 160
1X	1" sch xxs

** No sch for socket

ACCESS FITTING/TEE MATERIAL	
Code	Description
A	SA105 (Carbon Steel)
B	SA350 LF2 (Low Temp. Carbon Steel)
C	316 Stainless Steel
D	Alloy C276
E	Alloy 600
F	Alloy 625
G	Alloy 825
H	Alloy 2205 Duplex SS
I	SS Grade 254 SMO UNS S31254

PLUG + INJECTION NUT/ PACKING RETAINING NUT/ QUILL MATERIAL	
Code	Description
A	SA105/SA106gr B (Carbon Steel)
B	SA350 LF2/SA333 gr 6 (Low Temp. Carbon Steel)
C	316 Stainless Steel
D	Alloy C276
E	Alloy 600
F	Alloy 625
G	Alloy 825
H	Alloy 2205 Duplex SS
I	SS Grade 254 SMO UNS S31254

O-RING SEAL MATERIAL	
Code	Description
1	Viton®
2	Kalrez®
3	Nitrile
4	Ethylene Propylene

PRIMARY PACKING MATERIAL	
Code	Description
1	PTFE
2	Vespele®

COVER STYLE	
Code	Description
S	Standard

COVER MATERIAL	
Code	Description
A	SA105 (Carbon Steel)
B	SA333 gr 6 (Low Temp. Carbon Steel)
C	316 Stainless Steel
D	Alloy C276
E	Alloy 600
F	Alloy 625
G	Alloy 825
H	Alloy 2205 Duplex SS
I	SS Grade 254 SMO UNS S31254

NPT PLUG/SET SCREW MATERIAL	
Code	Description
S	316SS

STYLE OF QUILL/INJECTION PIPE	
Code	Description
1	Plain End
2	Mitered (45°)
3	Mitered (45° w/slot)
4	Mitered (30/60°)
5	Mitered (30/60° w/slot)
6	Nozzle (Inline)
7	Nozzle (90°)

INJECTION PIPE SIZE/SCHEDULE	
Code	Description
48	1/4" sch 80
46	1/4" sch 160
4X	1/4" sch xxs
88	3/8" sch 80
86	3/8" sch 160
8X	3/8" sch xxs
28	1/2" sch 80
26	1/2" sch 160
2X	1/2" sch xxs
38	3/4" sch 80
36	3/4" sch 160
3X	3/4" sch xxs

QUILL INSERTION LENGTH	
0013 to 4200 In 1/8 Quantities Example 26 7/8 = 2688	

VITON® is a registered trademark of the Chemours Co.

Kalrez® and Vespele® are registered trademarks of Dupont Polymers, Inc.

ASME® is a registered trademark of the American Society of Mechanical Engineers.



Spraying Systems Co.®
Experts in Spray Technology

North Avenue and Schmale Road, P.O. Box 7900, Wheaton, IL 60187-7901 USA

Tel: 1.800.95.SPRAY Intl. Tel: 1.630.665.5000
Fax: 1.888.95.SPRAY Intl. Fax: 1.630.260.0842

www.spray.com

